

INVENTA

derain



bonnard



matisse



atena



anteo



gris



dufy



cezanne



Desiderio di relax e comodità. Piena soddisfazione del proprio senso estetico. Emozioni da condividere con le persone care o da assaporare da soli in totale tranquillità.

Desire for relax and comfort. Fully satisfaction of one's own aesthetic sense. Emotions to be shared with the ones you love or to be enjoyed alone with peace and quiet.



derain

design Marzia Grossi





Linee curve ed avvolgenti per una soluzione d'arredo estremamente funzionale, in grado di personalizzare e reinventare ogni volta la gestione degli spazi.

Comfortable, curved lines for an extremely functional sofa able to personalize and reinvent the management of spaces every time.





r i e p i l o g a n d o

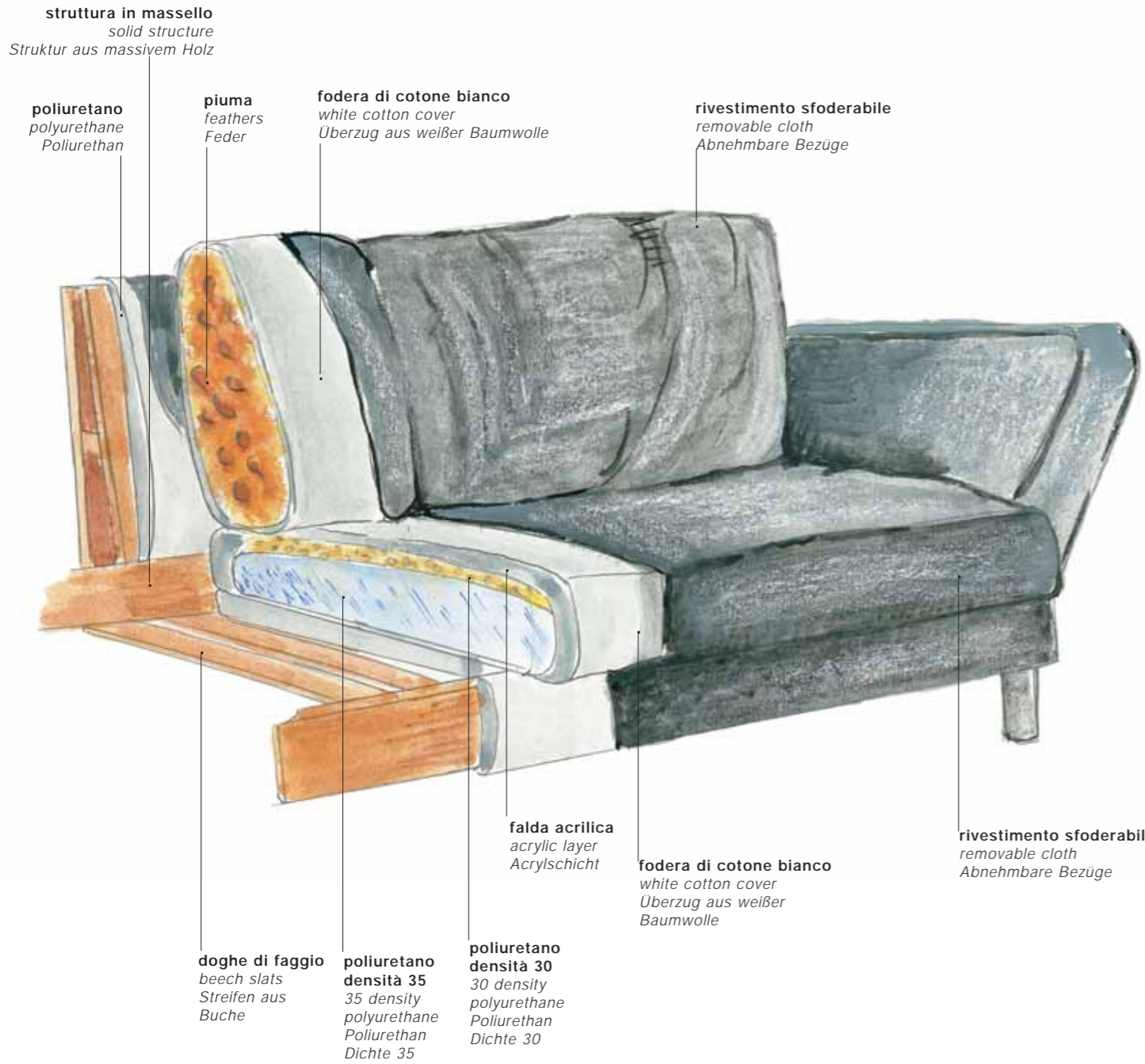

È possibile effettuare la scelta del piedino in metallo oppure in legno (nelle varianti rovere o wengè).
Metal or wooden (oak or wengè) foot available.



Divani

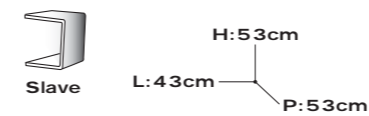
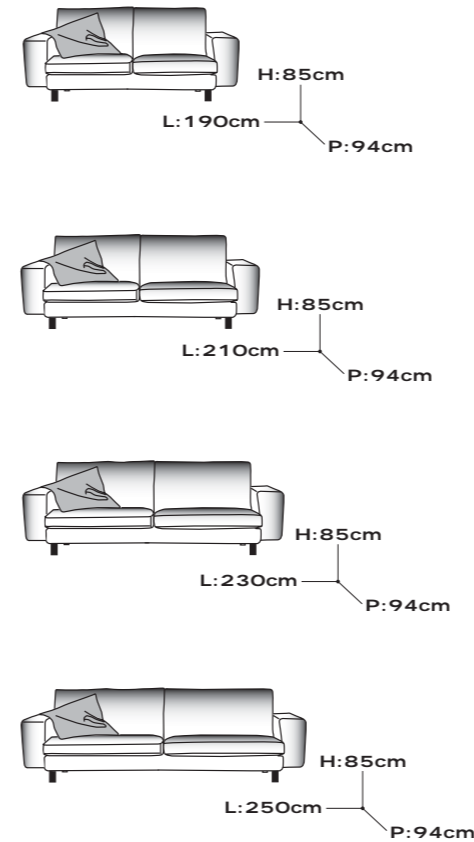

Terminali Dx o Sx

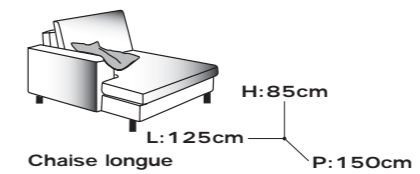
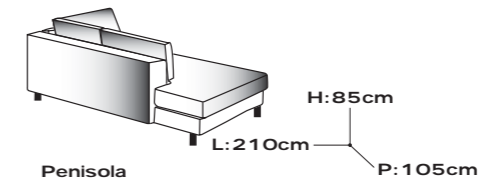
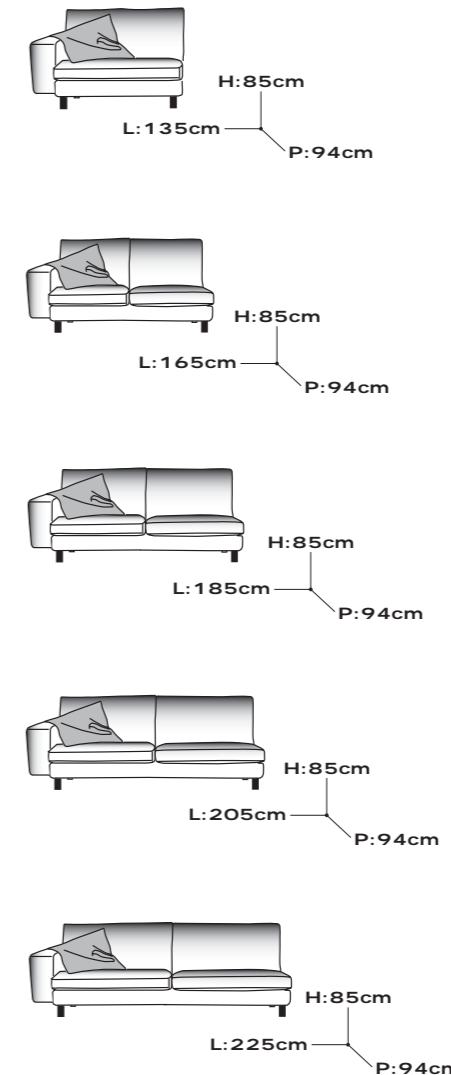

Terminali Stondati Dx o Sx

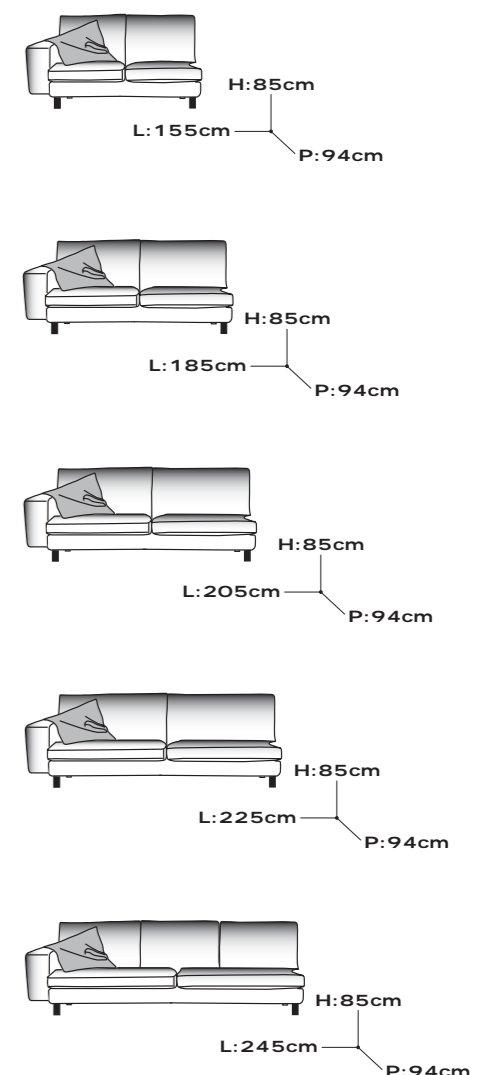

Di forte impatto visivo, sa distinguersi per le decise linee architettoniche luminose e vitali, in grado di percepire lo spazio circostante.

Strong visual impact and bright and vital strong architectural lines for a sofa able to perfectly merge with the surrounding environment.



matisse
design Marzia Grossi





Un progetto di grande rigore: carattere deciso, per uno stile dalle forme pure, partner ideale di qualsiasi ambiente.
A very rigorous sofa with a strong character and pure forms that perfectly suits all environments.



Originalità e funzionalità per il tavolino a servizio, studiato con grande attenzione anche nei minimi dettagli.

Original and functional side-table designed in detail with greatest care.





r i e p i l o g a n d o

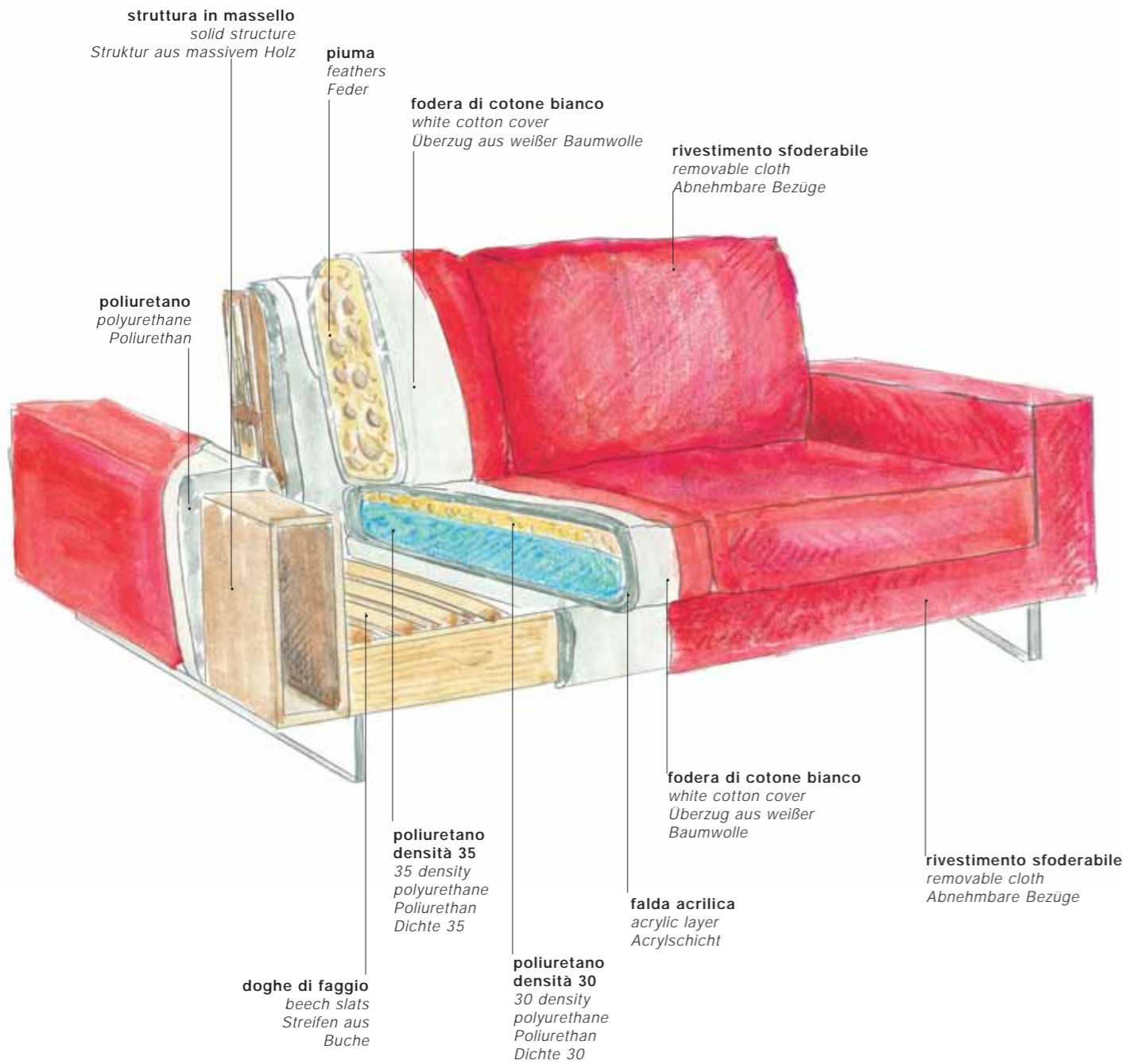

Possibilità di scegliere tra due diverse finiture per quanto riguarda i piedini: a slitta oppure tradizionale (entrambi in metallo).

Feet available with sled or traditional metal finishing.



Divani

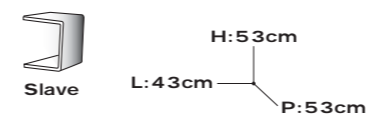
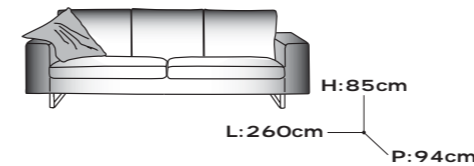
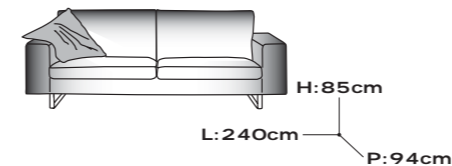
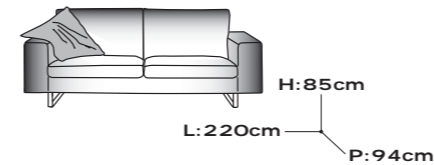
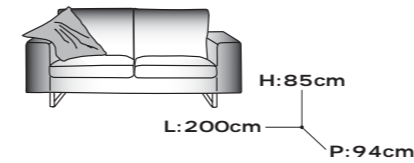
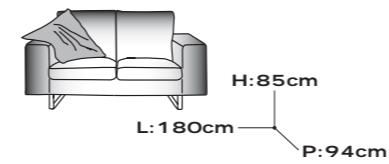

Terminali Dx o Sx

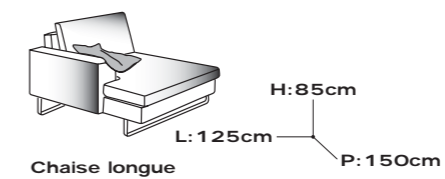
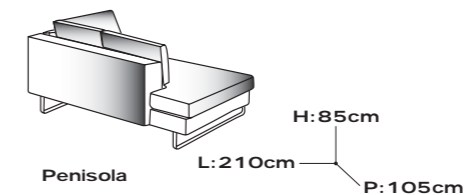
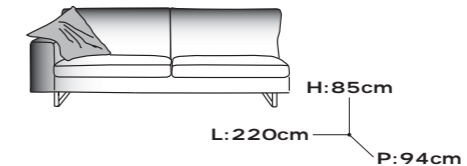
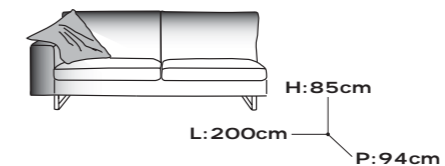
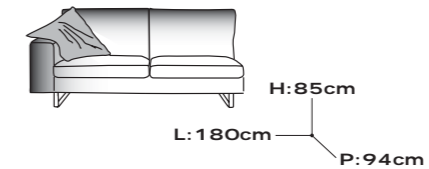
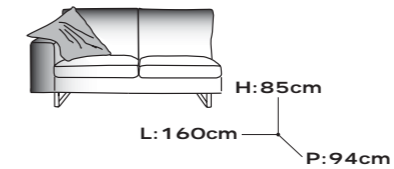
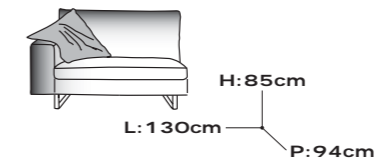

Terminali Stondati Dx o Sx

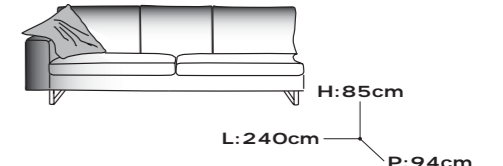
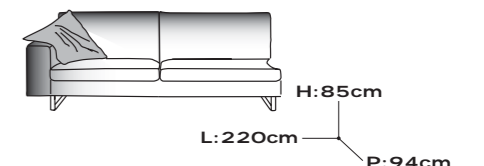
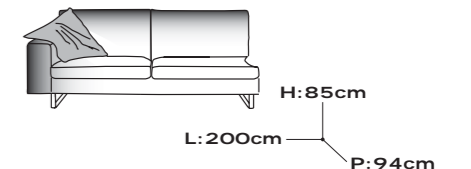
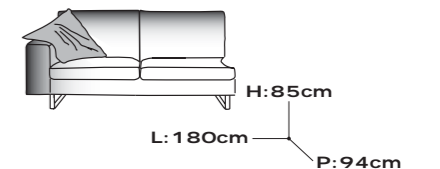
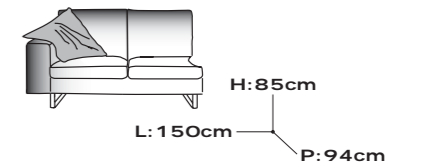

Un nome che evoca subito atmosfere classiche. Design netto, giocato sull'equilibrio delle linee, che crea un sobrio rigore, stemperato dai due cuscini pensati come bracciolo.

A name immediately evoking classic atmospheres. Clear design based on the balance of the lines, which creates sober rigour softened by two cushions designed as arm-rests.



anteo
design Giorgio Manzali







r i e p i l o g a n d o

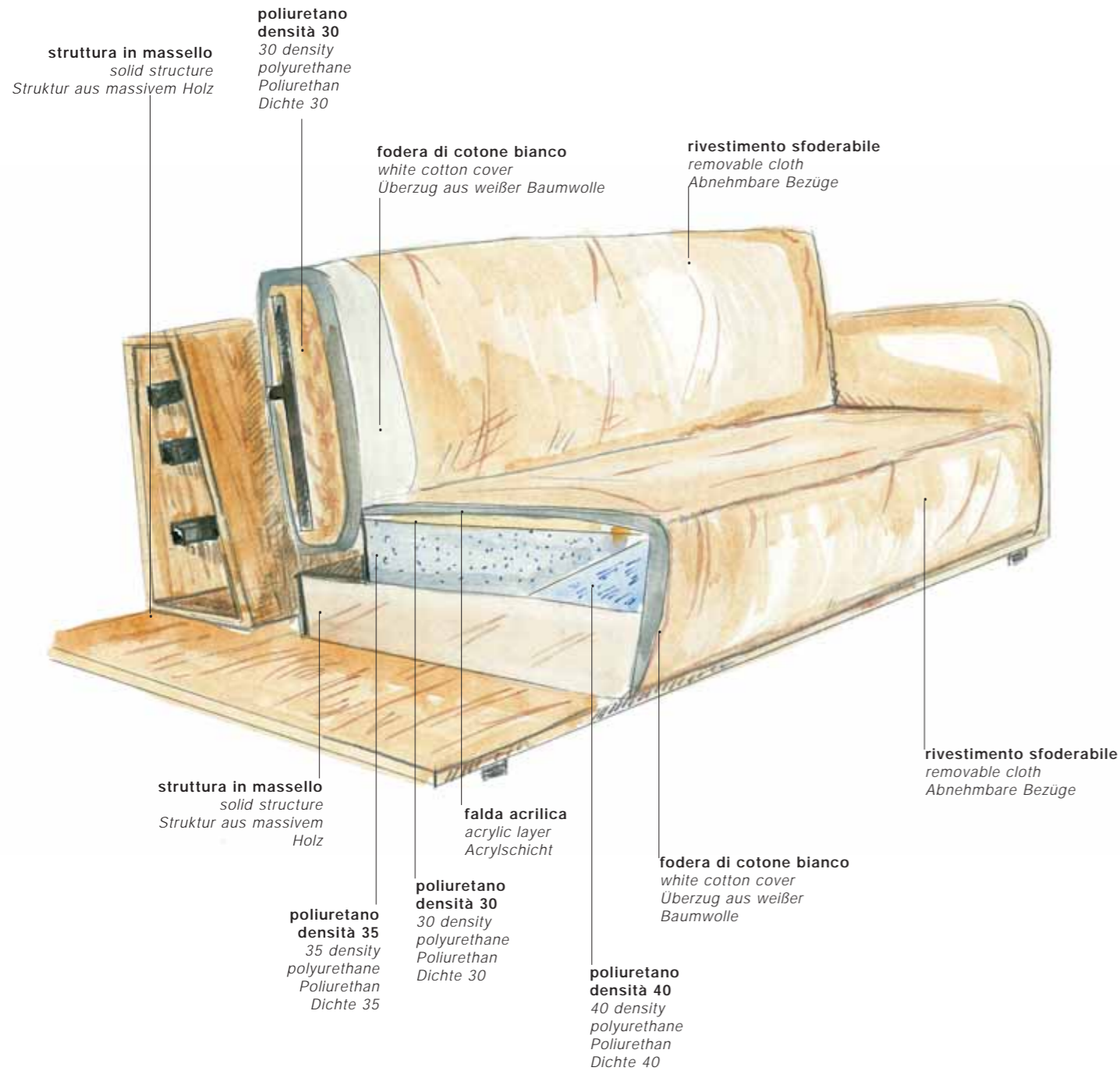

Divani

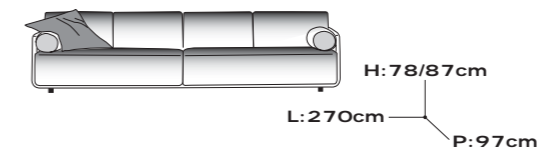
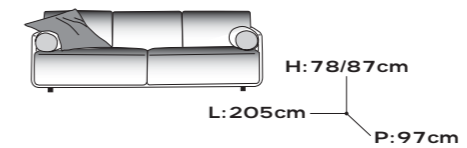
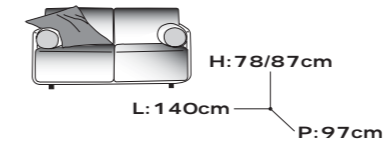

La possibilità di posizionare lo schienale a due altezze differenti, per un comfort ancora maggiore.

The backrest can be positioned at two different heights for even greater comfort.



Due differenti soluzioni per il piedino in legno: rovere o wengè.

Wooden foot available in the oak or wengè version.

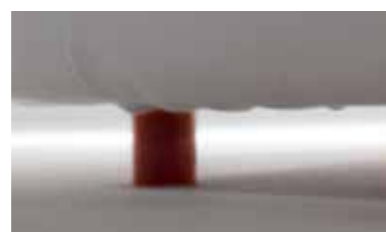
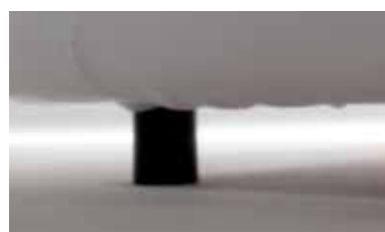

Forme geometriche solide ed una gamma di tonalità di grande calore, per vivere piacevoli momenti di intimità in un'atmosfera decisamente lounge.

Solid geometric forms and a range of very warm colours to live pleasant moments of intimacy in a lounge atmosphere.



dufy
design Giorgio Manzali









Le diverse composizioni sono state pensate per creare, ogni volta, ideali soluzioni aperte e funzionali, mai convenzionali.

The different compositions have been designed to create every time open and functional ideal solutions which are never conventional.



r i e p i l o g a n d o

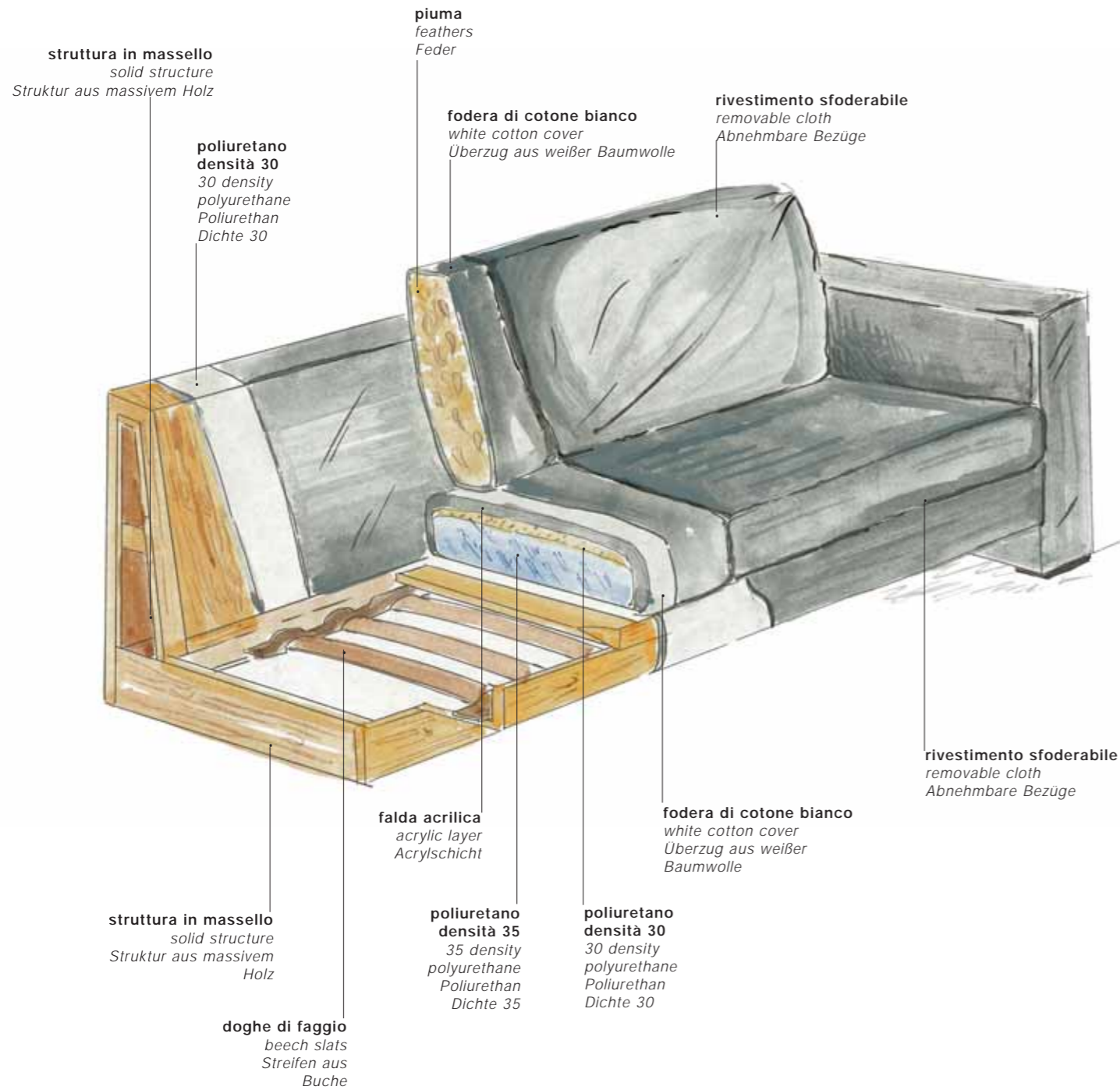

Divani

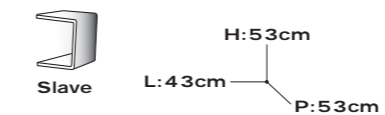
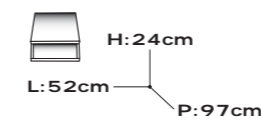
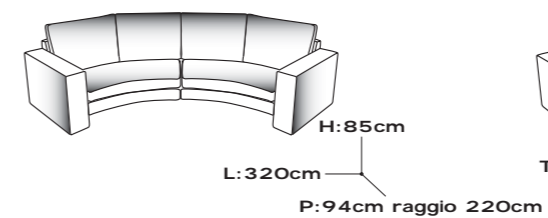
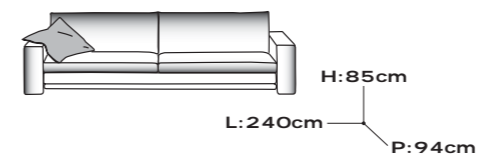
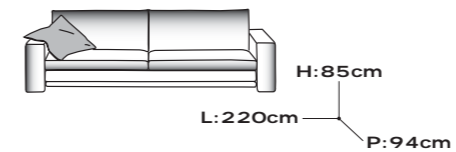
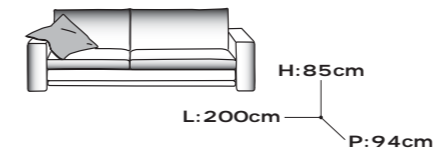
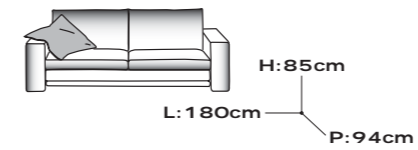
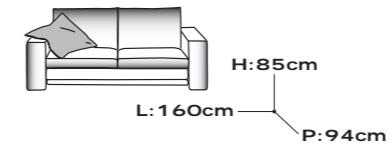

Terminali Dx o Sx

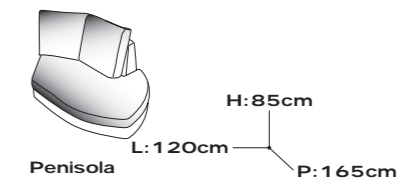
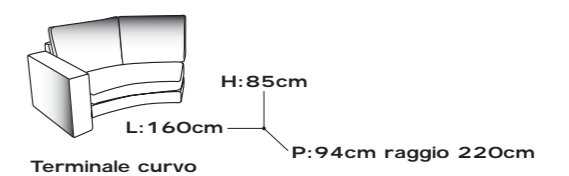
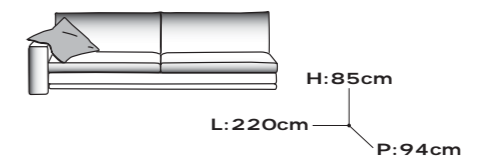
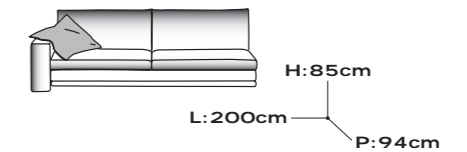
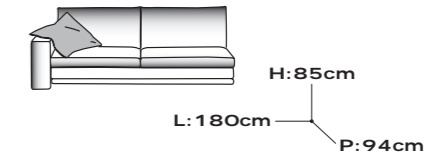
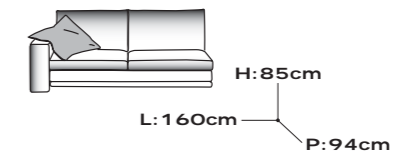
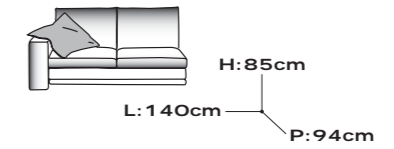

Linee essenziali di grande armonia e versatilità, per dialogare con estrema naturalezza e semplicità con l'ambiente che sta intorno.

Essential lines featuring great harmony and versatility for a sofa perfectly merging with the surrounding environment in a very simple and natural way.



bonnard

design Marzia Grossi









r i e p i l o g a n d o

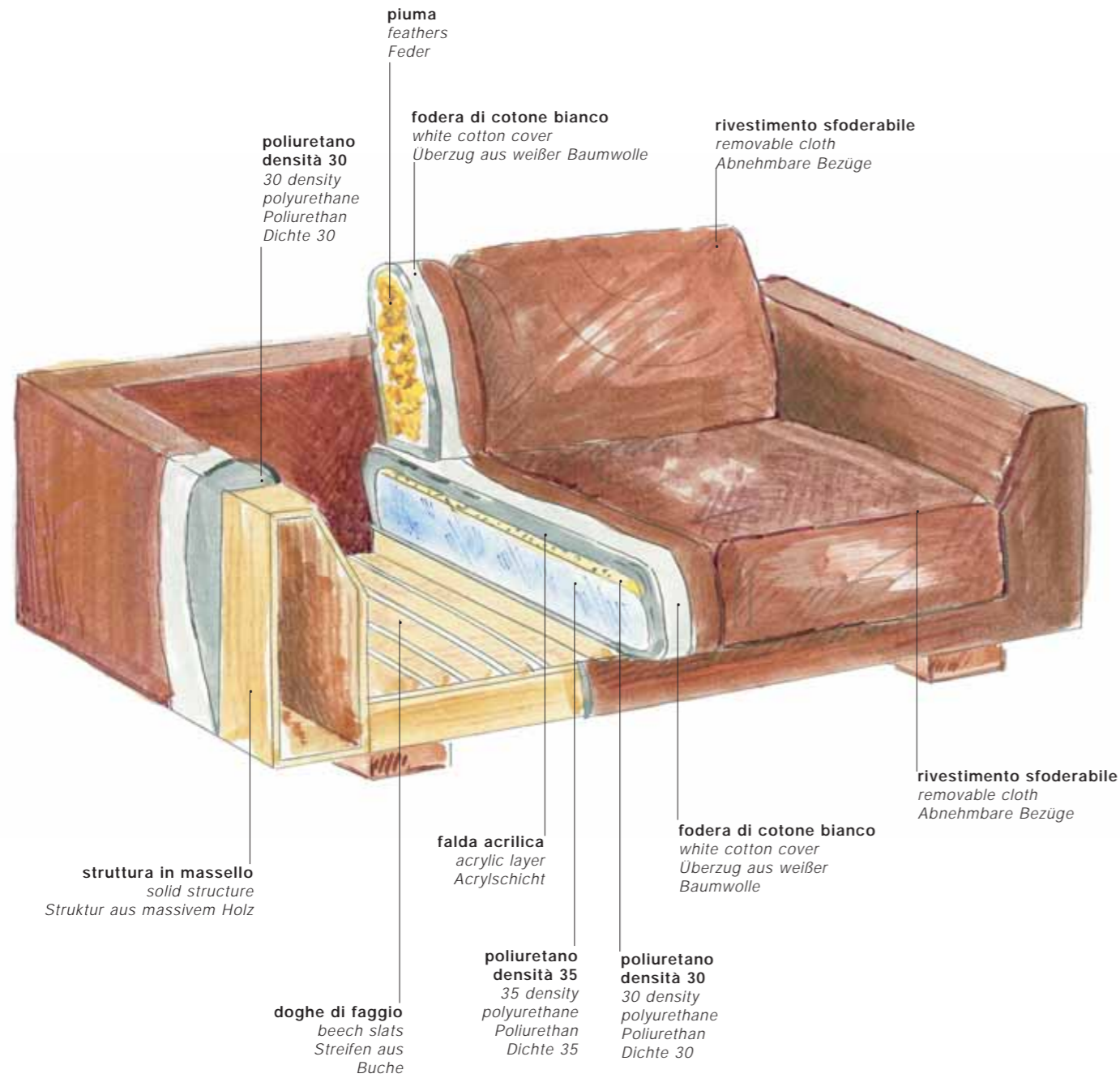

Alternativa cromatica per i piedini: rovere o wengè.

Feet available in the oak or wengè version.

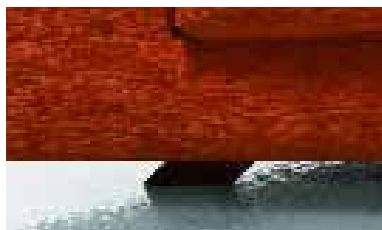

Divani

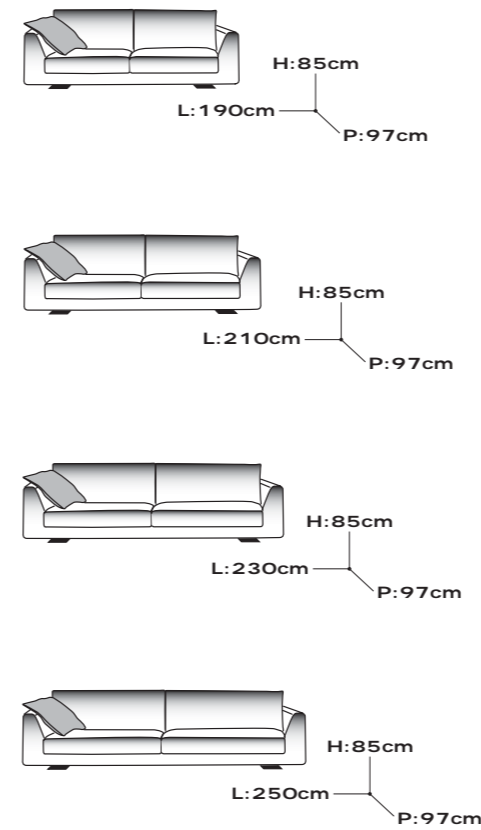

Terminali Dx o Sx

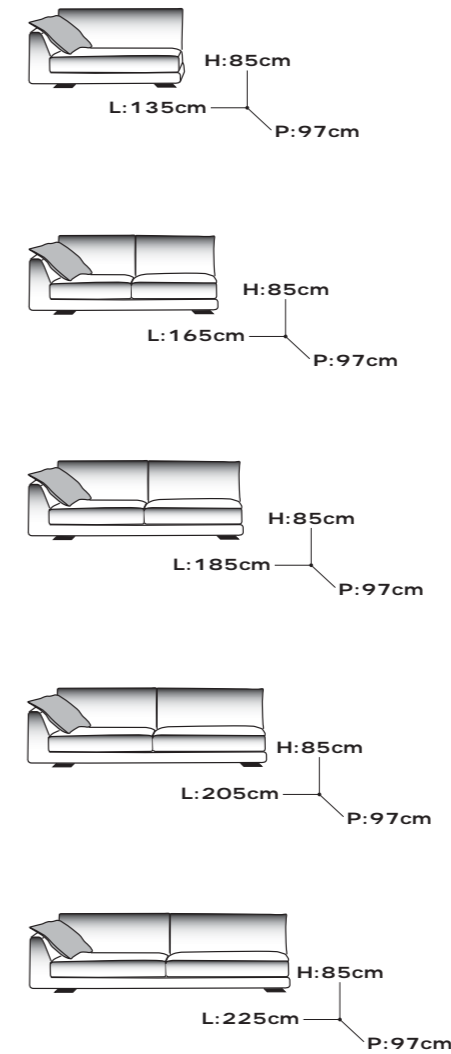

Terminali Stondati Dx o Sx

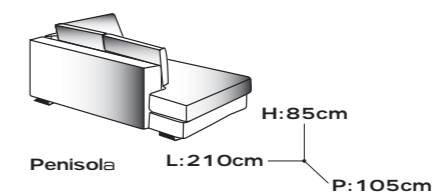
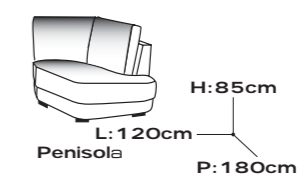
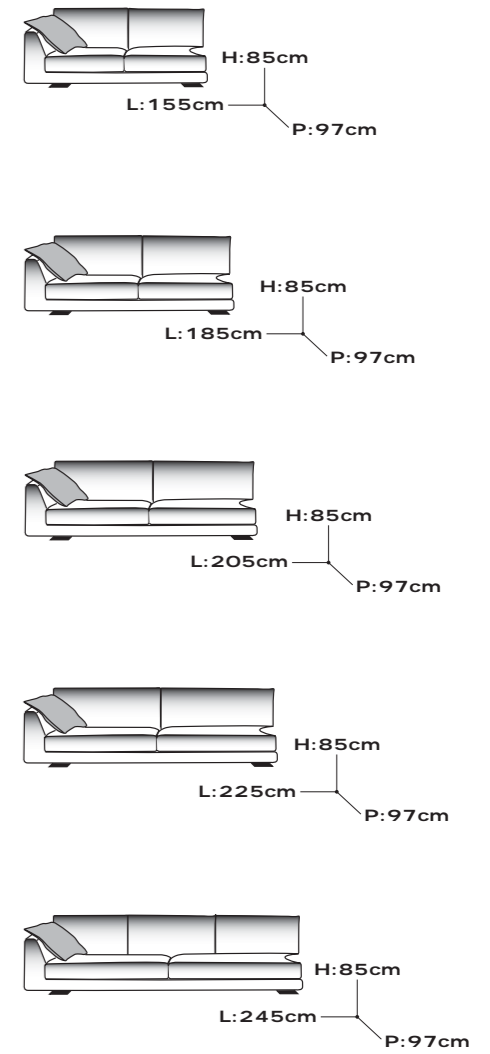

Design vagamente retrò, che ad uno sguardo più attento rivela però un'anima contemporanea, per ridefinire in modo estremamente personale gli spazi abitativi.

A little retro design, which, when looking at it more carefully, reveals a contemporary soul to redefine the living spaces in an extremely personal way.



atena
design studio Galantini





r i e p i l o g a n d o

Poltrone

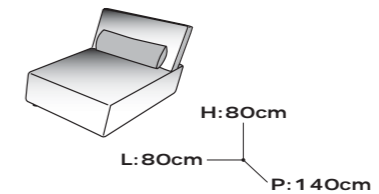
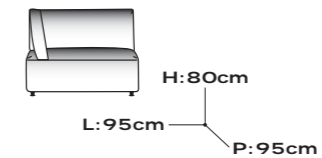
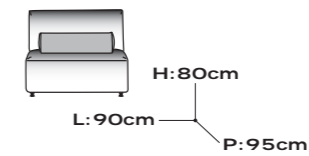
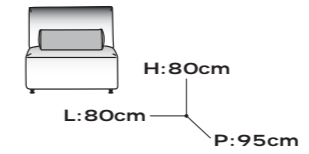

Azionando un semplice meccanismo su tre differenti posizioni, è possibile trovare sempre quella ideale di riposo.
A simple mechanism allows it to be placed in three different positions to always find the ideal resting position.

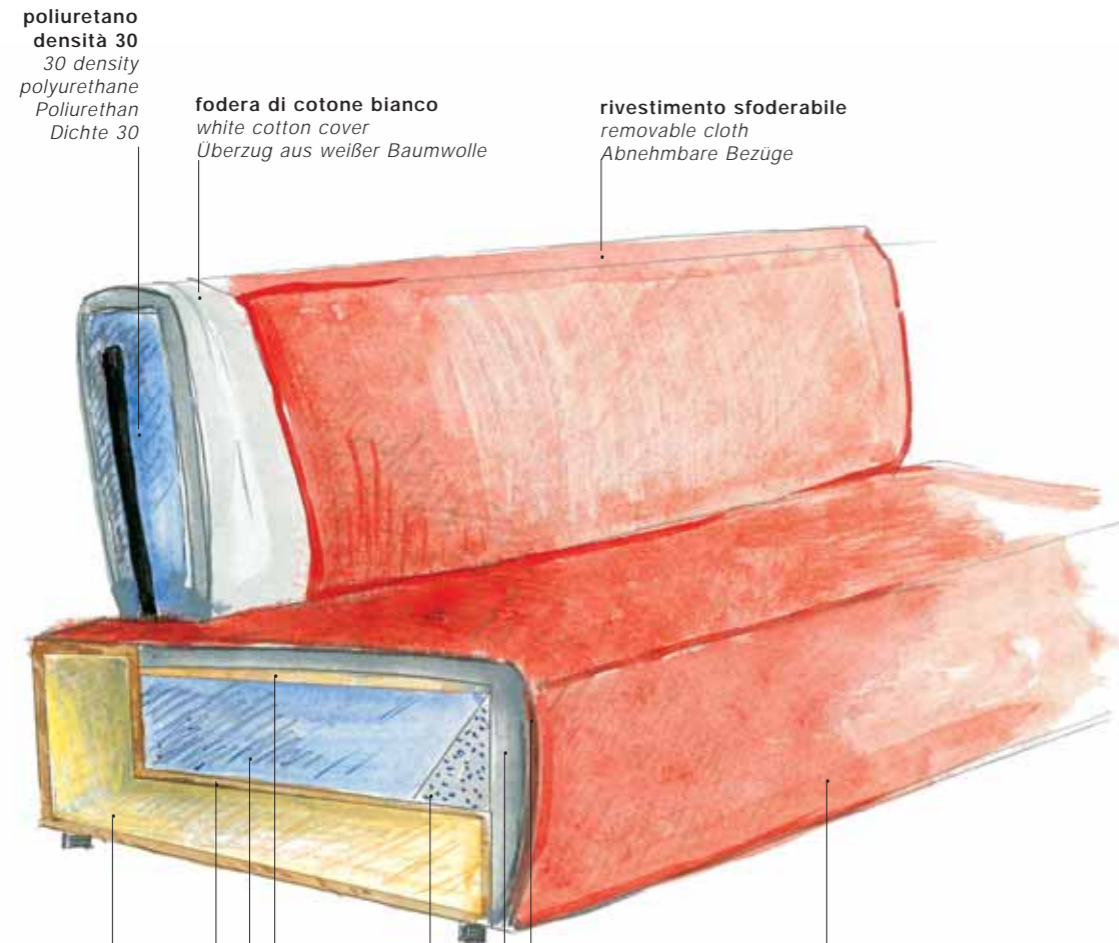

poliuretano
densità 30
30 density
polyurethane
Poliurethan
Dichte 30

fodera di cotone bianco
white cotton cover
Überzug aus weißer Baumwolle

rivestimento sfoderabile
removable cloth
Abnehmbare Bezüge

struttura in massello
solid structure
Struktur aus massivem Holz

doghe di faggio
beech slats
Streifen aus
Buche

poliuretano
densità 35
35 density
polyurethane
Poliurethan
Dichte 35

poliuretano
densità 30
30 density
polyurethane
Poliurethan
Dichte 30

poliuretano
densità 30
30 density
polyurethane
Poliurethan
Dichte 30

falda acrilica
acrylic layer
Acrylschicht

fodera di cotone bianco
white cotton cover
Überzug aus weißer
Baumwolle

rivestimento sfoderabile
removable cloth
Abnehmbare Bezüge

La progettazione di un divano parte sempre dall'idea di dare forma ad un intreccio di linee geometriche, per creare di volta in volta nuovi volumi di continuità.

The design of a sofa always starts from the idea of giving shape to a tissue of geometric lines to create every time new volumes of continuity.



gris
design Marzia Grossi



Un equilibrato gioco tra pieni e vuoti, in grado di offrire funzionalità e comodità, per rendere il divano un luogo di comfort assoluto.

A balanced play of solid and empty elements able to offer great comfort and functionality in order to make your sofa an extremely comfortable place.







r i e p i l o g a n d o

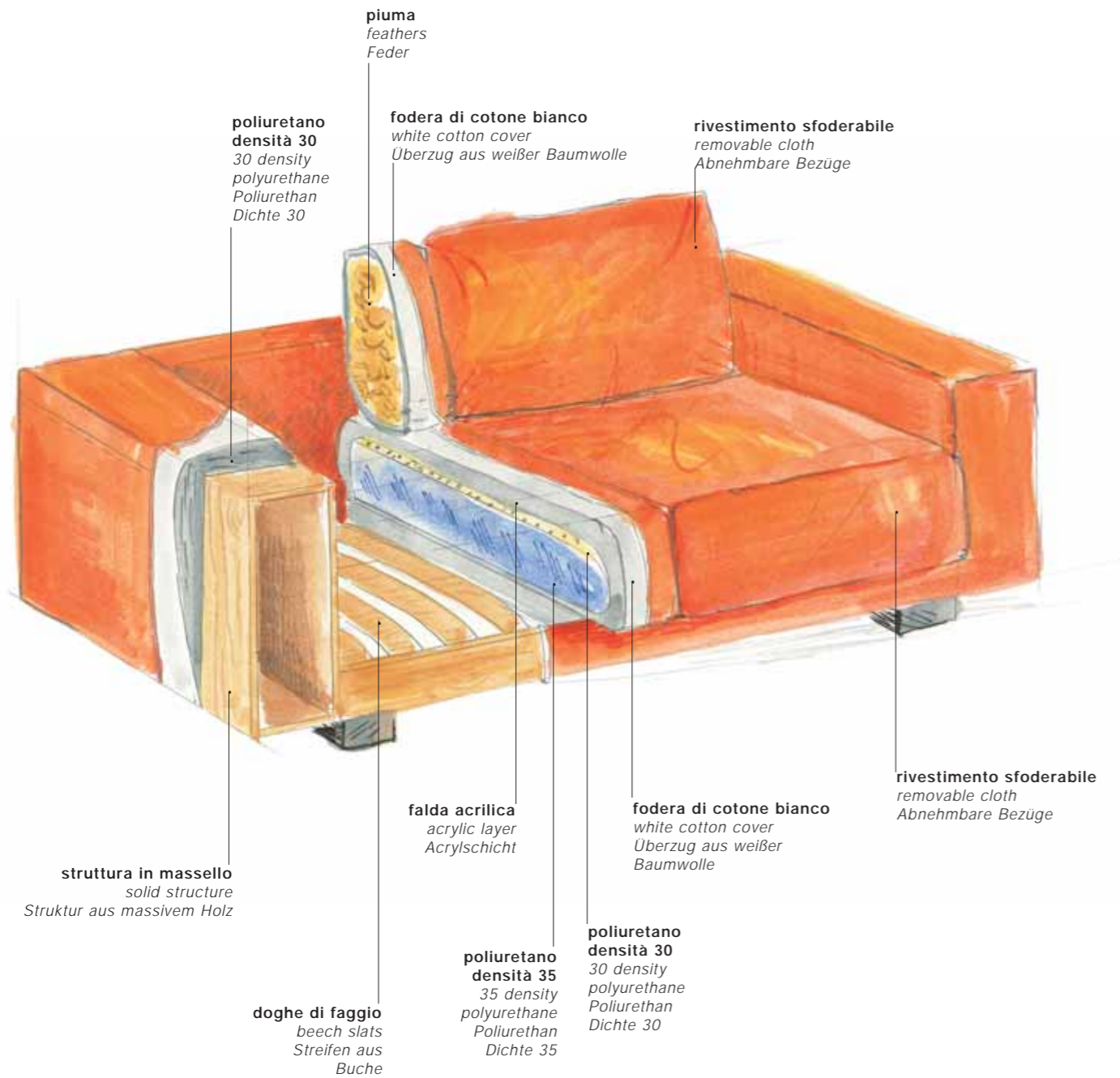

Originale design per i piedini, proposti in due differenti varianti di colore: rovere o wengè.

Original design for the feet, which are available in two different colours: oak or wengè.



Divani

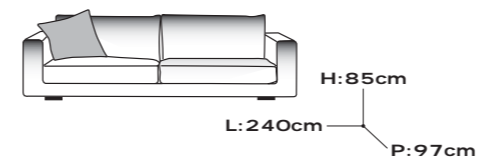
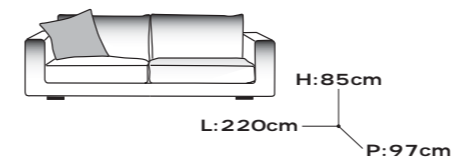
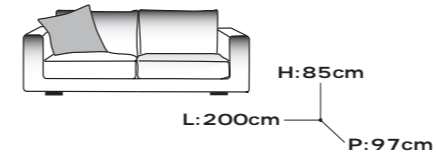
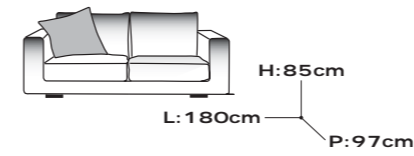

Terminali Dx o Sx

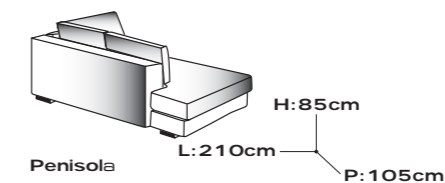
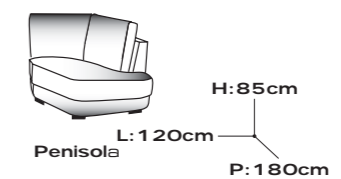
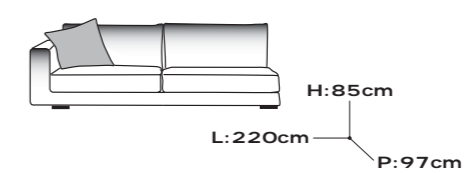
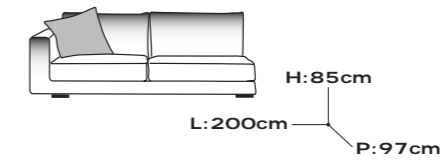
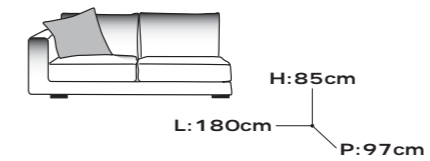
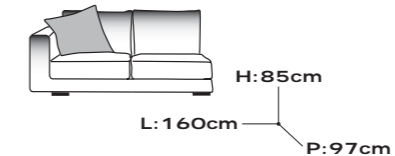
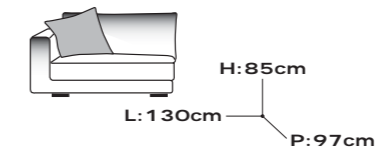

Terminali Stondati Dx o Sx

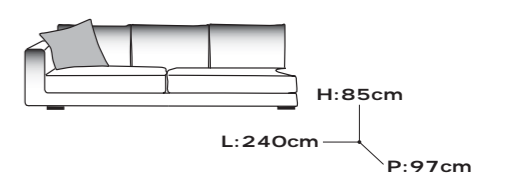
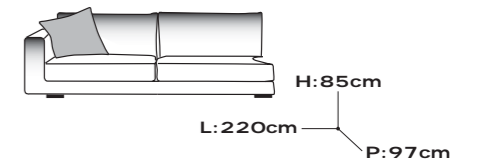
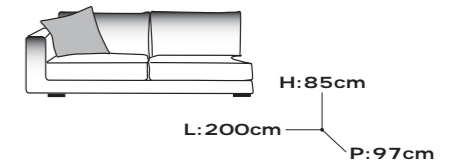
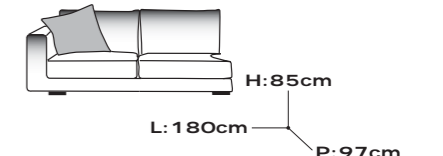

Versatilità e praticità come prerogative imprescindibili, per adattarsi perfettamente a qualsiasi ambiente: fresco ed informale oppure elegante e raffinato.

Versatility and functionality as essential characteristics to perfectly suit all environments, from the fresh and informal ones to the elegant and refined ones.



cezanne
design Marzia Grossi







Design accentuato, quasi esasperato, per una chaise-longue che definisce in modo netto lo spazio in cui viene collocata: un'oasi di puro relax dalla forma esclusiva.

Almost extreme, marked design for a chaise longue strongly characterizing the space in which it is placed. A pure oasis of relaxation with an exclusive shape.

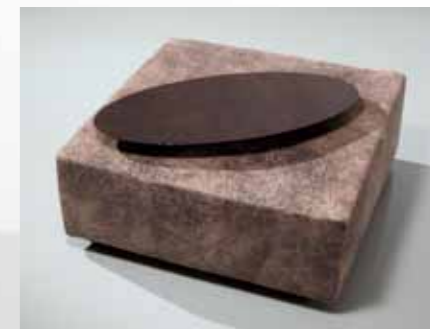

r i e p i l o g a n d o

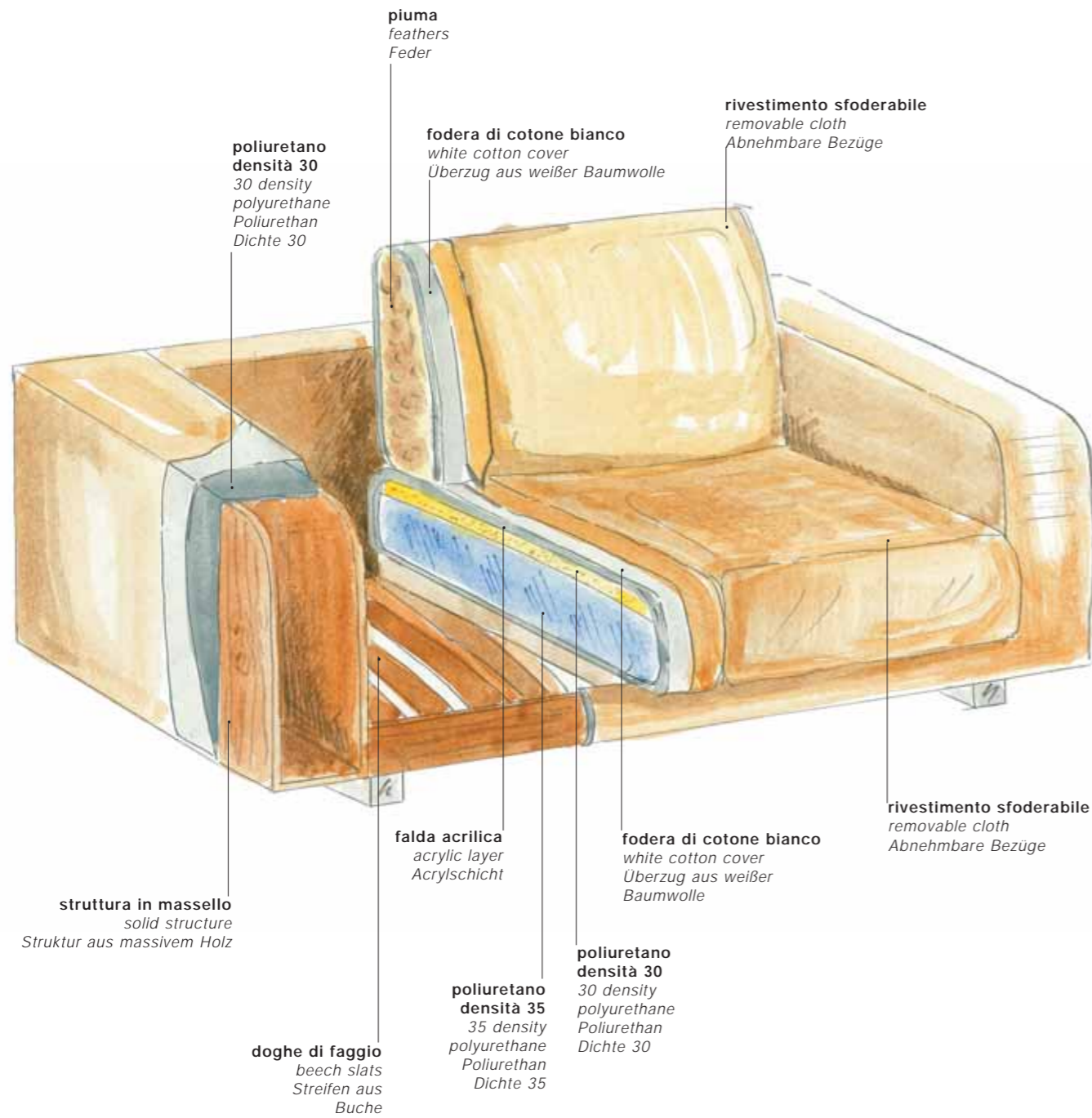

Rovere o wengè: due soluzioni alternative, per rispondere al meglio alle differenti esigenze di arredo.

Oak or wengè: two alternative solutions to fully satisfy all furnishing requirements.



Divani

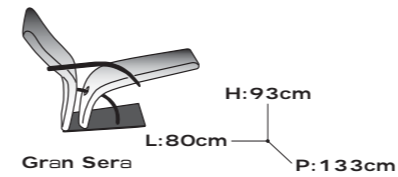
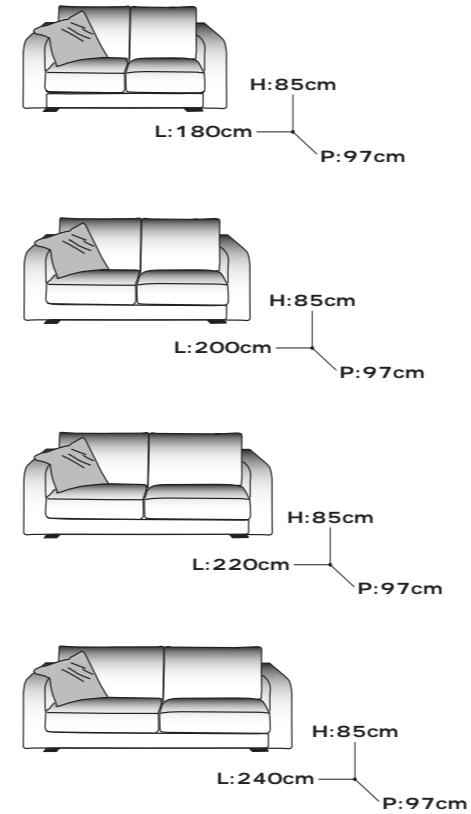

Terminali Dx o Sx

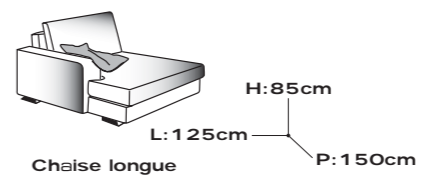
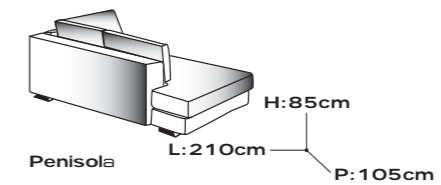
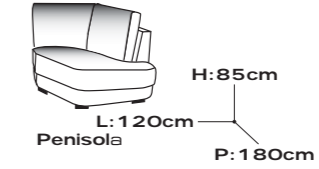
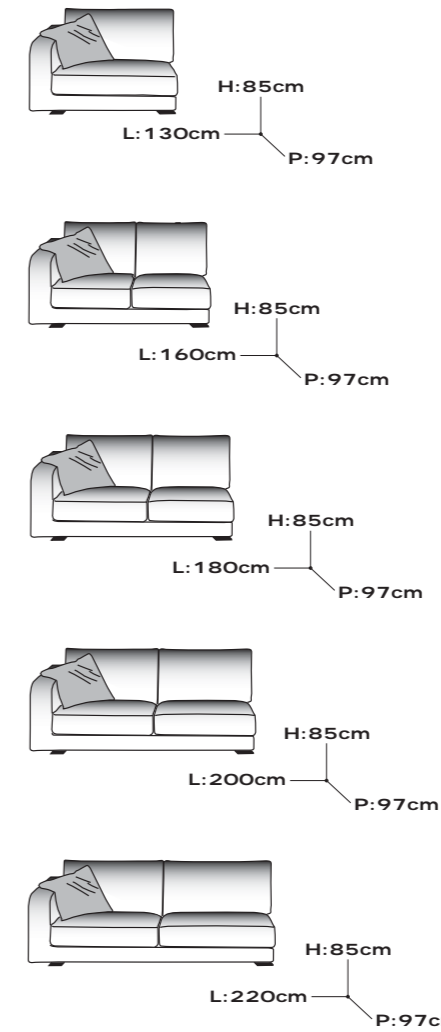

Terminali Stondati Dx o Sx

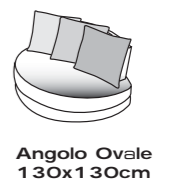
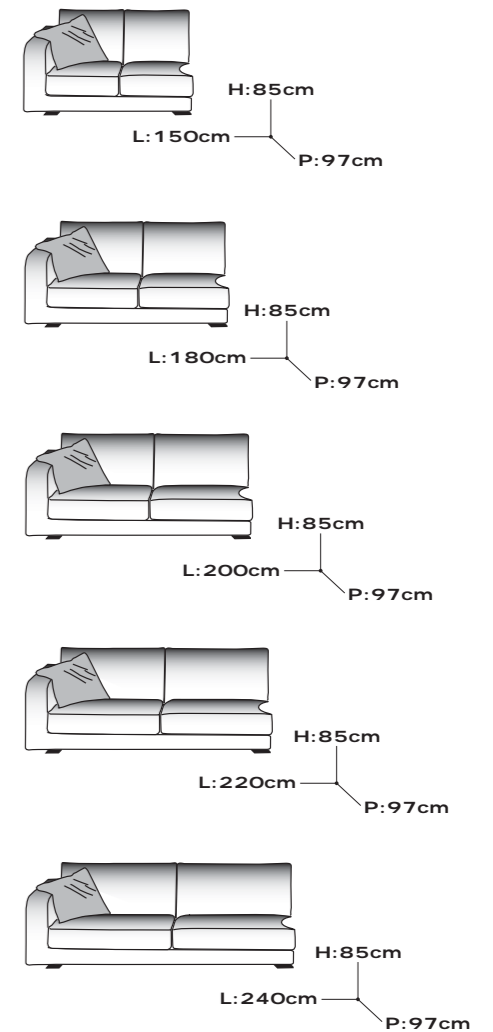

Art director:
Marzia Grossi

Photography:
Black Studio 2 (PU)

Pre-press:
Over cover

Graphic design:
Gian Claudio Emiliani

Copy:
Carlo Lisciotto

Printing:
Brighi e Venturi (Cesena - FC)

settembre 2006



Via Pantanelli, 192 - 61025 Montelabbate (PU) - Italy
tel. +39 0721 490308 - fax +39 0721499408
www.inventa-italy.com
inventa@inventa-italy.com