

THIRTY
ETH

30

ANNIVERSARY

BOOK 1

INVENTA
CONTRACT



CONTRACT
MADE in

ITALY

INVENTA

Cari amici,

gli spazi dell'effimero si sono allontanati in tempo breve e veloce, in linea continua e senza intervalli, dalle abitudini del nostro quotidiano. Queste modifiche, queste trasformazioni, questi cambiamenti sociali marcano lo stile delle forme attorno al nostro vivere: un sottofondo costante, un basso continuo che ci accompagna con presenza ininterrotta. Ogni attività produttiva ha uno specchio di domande, ormai divenute comuni, alle quali è sempre più necessario dare risposte mirate e puntuali. Ora, con questi Book Uno e Due, vogliamo dare risposte, mirate e puntuali, che escano dal Solito ed entrino con apparente semplicità nell'area dell'Insolito, non come fine ma come valore e tramite creativo; tutto questo lo intendiamo come Ricerca, Emozione, Intuizione ed infine Soluzione progettuale per offrire poltrone e divani che siano prima elementi di socializzazione e che si aprono poi verso una vita colorata.

Giordano e Alex Del Prete

Dear Friends.

It didn't take too long for the Ephemeral to leave – rapidly, quickly and pause less – the spaces of our daily living. The alterations, the transformations and the social changes have a deep influence on the shapes around us: a continuous bass note that follows us with its break less noise, like an incessant background. All Manufacturers have to face a range of challenges, which are more and more demanding and difficult to meet. These Books One and Two are aimed at giving precise and correct answer, leaving the Usual behind and getting with apparent simplicity into the area of the Unusual, not meaning it as a final purpose, but as a value and as a creative tool. We mean all this as Research, Emotion, Intuition and – at the end of the journey – as the Solution of our problem: how to design soft furniture being at the same time socializing units and open doors to a more colourful life.

Giordano e Alex Del Prete





POLTRONE E DIVANI SONO ELEMENTI DI SOCIALIZZAZIONE CHE APRONO AD UNA VITA COLORATA

INDEX



Plug and play 8 • 11



Grenada 12 • 15



Rebound 18 • 19



Flexy 20 • 21



Robespierre 22 • 25



Bibi 26



Barny 27 • 31



Bench 32 • 35

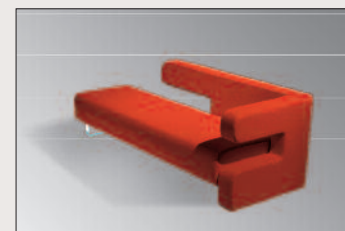

Ruby 36 • 37



Tobago 38 • 41



Eos 42 • 45



Barbados 46 • 49

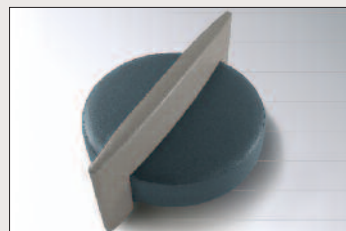

Rolly 52 • 53



Helis 54 • 57

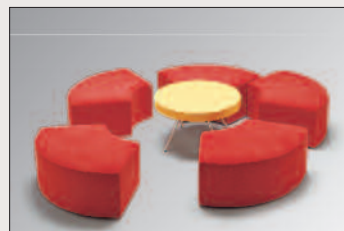

Daisy 58 • 61



Daisy 58 • 61



Fred 62 • 67



Dominica - Martinica 68 • 69



Punto 70 • 71

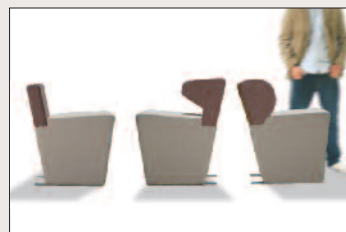

Coffee 74 • 79



Cappuccino 80 • 83



Carla - Carlotta 84 • 85



Hug-me 86 • 87



Virgola 88 • 89



Trace big&small 90 • 91



Frutta&verdura 92 • 93

plug and play

design Studio Galantini



Fusto in legno rivestito in poliuretano espanso
ignifugo indeformabile a densità differenziata.
Piede in acciaio cromato.
Il modello non è sfoderabile.

Wooden frame covered with stressresistent polyurethane
foam at varied densities. Flame retardant.
Feet in steel cromate finish.
No removable covers.

Structure en bois recouverte de mousse de
polyuréthane non feu à densités différenciées.
Pieds en acier chromé.
L'élément n'est pas déhoussable.

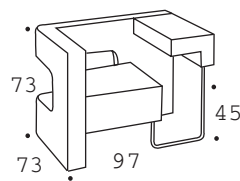

MI GIRO UN PO' E HO IL MIO BOOK MI RIGIRO E GUARDO LA TVU', MI RIGIRO ANCORA? YES, I CAN!

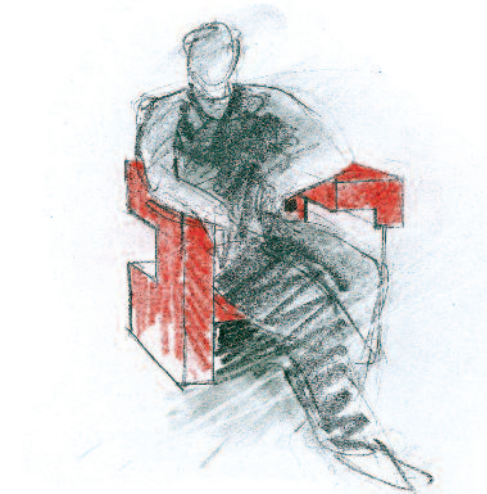

Quello che per molti potrebbe essere un motivo di stile, cioè la poltrona disegnata riga e squadra, diventa la funzione razionale del progetto. Seduta e schienale sono spessorati in poliuretano così da permettere ampia comodità qualsiasi posizione si voglia assumere.



For many it might just be a stylish performance, one of the countless armchairs designed using ruler and triangle, but soon you realize that it is above all the result of a rational project. Seat and back are rich in polyurethane foam, thus offering a wide comfort in any sitting.

Ce qui pour beaucoup ne pourrait être qu'un motif de style, c'est-à-dire un fauteuil dessiné à la règle et à l'équerre, devient la fonction rational du project. Siège et dossier sont riches en mousse de polyuréthane pour offrir un grand confort en toutes positions d'assise.

LA FORMA QUADRATA E LIBERA ENTRA NELLA FUNZIONE IN MODO RAZIONALE

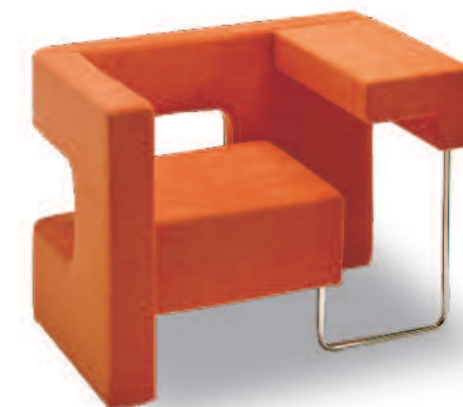

grenada

design Giorgio Manzani



Fusto in legno rivestito in poliuretano espanso
ignifugo indeformabile a densità differenziata.
Piede in acciaio cromato.
Il modello non è sfoderabile.

Wooden frame covered with stressresistent polyurethane
foam at varied densities. Flame retardant.
Legs in steel cromate finish.
No removable covers.

Structure en bois recouverte de mousse de
polyuréthane non feu à densités différenciées.
Pieds en acier cromé.
L'élément n° est pas déhoussable.

Prof./Depth 82

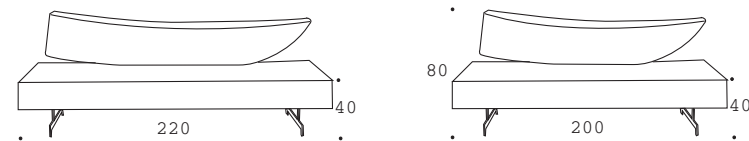

UN MOMENTO DI SINTESI
CONIUGA GESTO CURVO DELLO SCHIENALE
E LINEARITA' DELLA SEDUTA



Il linguaggio delle cose rappresenta una freccia di penetrazione nella fantasia e nei desideri tanto da modificare i valori delle necessità funzionali. La grande virgola-schienale è il segno distintivo, la parola incisiva del linguaggio Grenada.

The language of the objects is an arrow piercing into the fantasy and the desires, as it almost changes the value of the functional needs. The big comma-shaped back of Grenada is its distinctive mark, the sharp word of its language.

Le langage des objets est une flèche qui perce la fantasia et les désirs, de sorte qu'il modifie les valeurs des nécessités fonctionnelles. Le grand dossier en forme de virgule de Grenada est son signe distinctif, le mot incisif de son langage.

IL LINGUAGGIO DELLE COSE È UNA FRECCIA CHE PENETRA I DESIDERI



POSSIAMO REALIZZARE E PRODURRE MODELLI DI SEDUTE PROGETTATE O DA
WE CAN DEVELOP AND MANUFACTURE ANY KIND OF CONTEMPORARY SEATING
NOUS POUVONS RÉALISER ET FABRIQUER DES MODÈLES DE SIÈGES DESSINÉS EN

PROGETTARE IN COLLABORAZIONE CON ARCHITETTI E CONTRACT DESIGNERS NELL'INTERESSE DI SVILUPPARE INSIEME UNA COLLABORAZIONE PERSONALIZZATA
FURNITURE, IN COOPERATION WITH ARCHITECTS AND CONTRACT DESIGNERS, BUILDING UP WITH THEM A PERSONALIZED TEAM WORK.
COLLABORATION AVEC ARCHITECTES ET DÉCORATEURS DE COLLECTIVITÉS ET SOMMES DISPONIBLES À DÉVELOPPER AVEC EUX UNE COOPÉRATION PERSONNALISÉE.

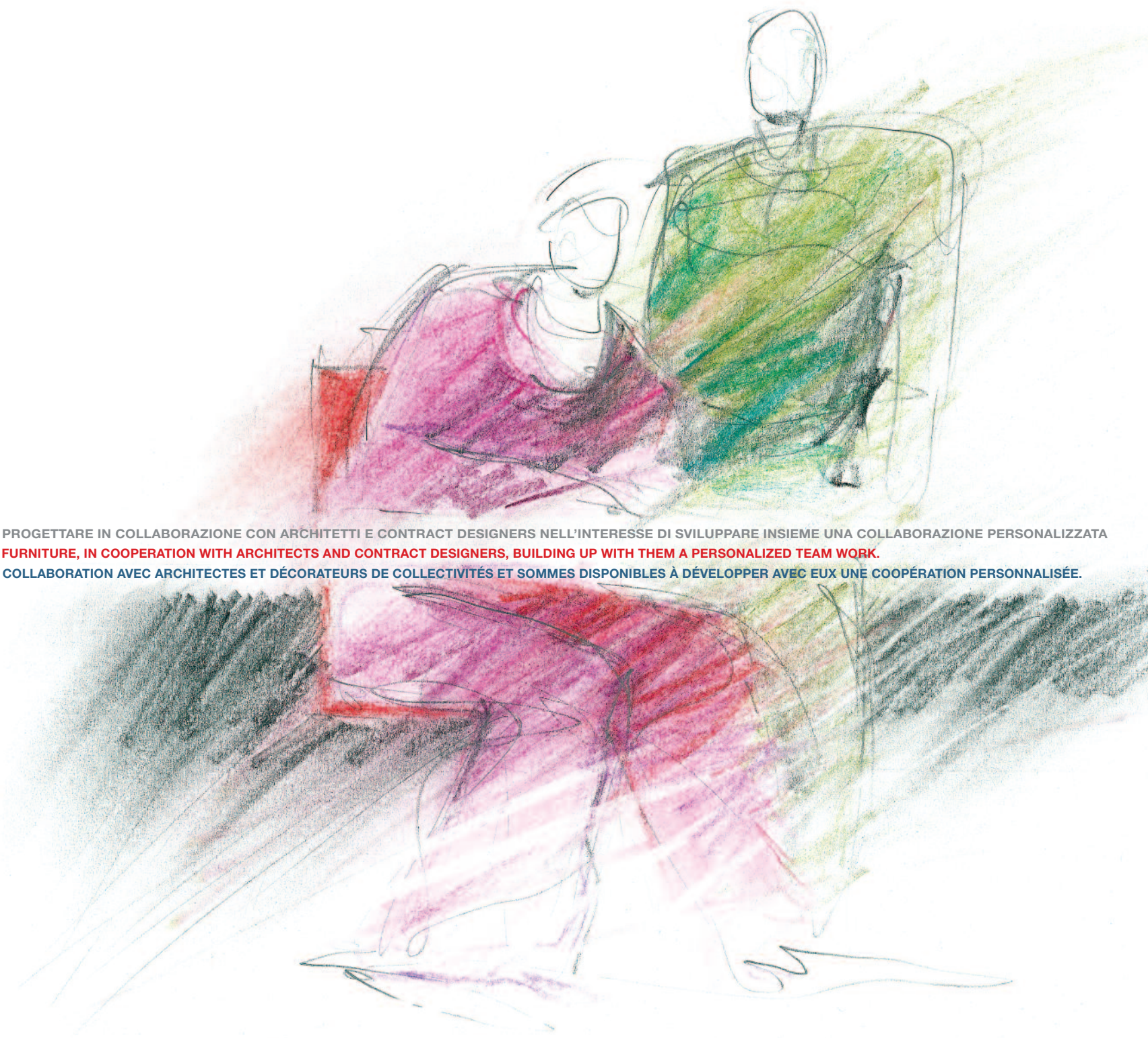

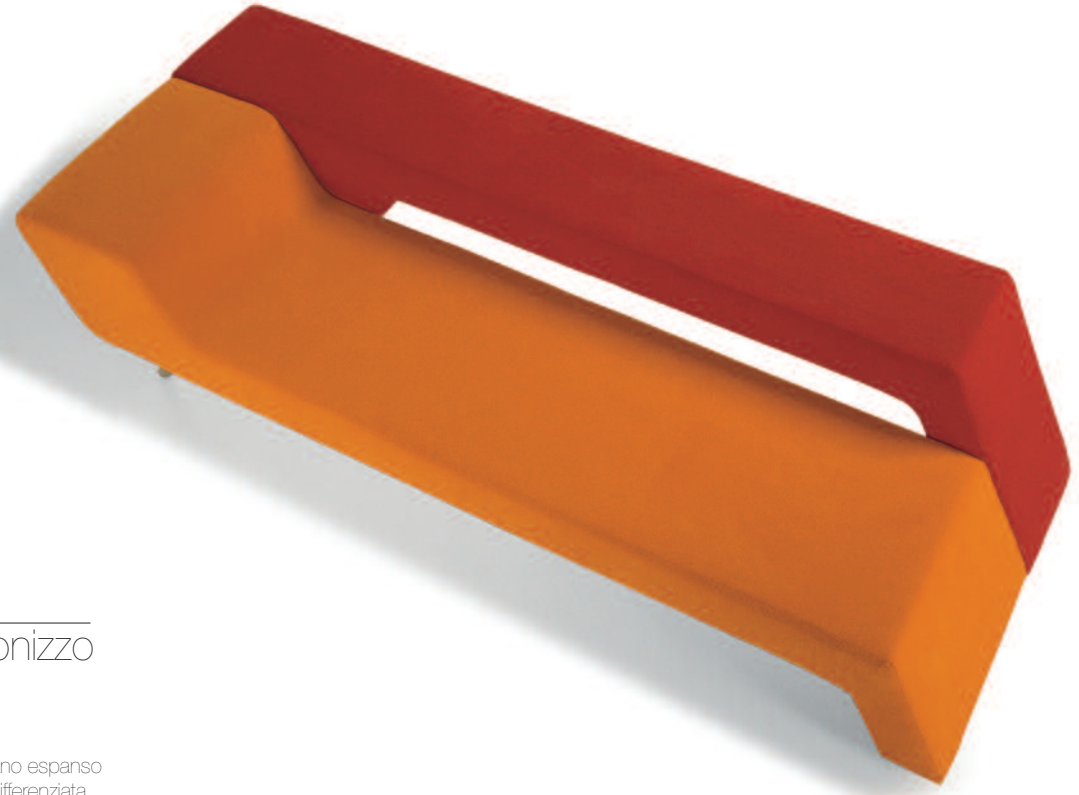

rebound
design Davide Tonizzo

Fusto in legno rivestito in poliuretano espanso ignifugo indeformabile a densità differenziata. Piede in metallo verniciato alluminio. Il modello non è sfoderabile.

Wooden frame covered with stressresistent polyurethane foam at varied densities. Flame retardant. Feet in metal polished aluminium. No removable covers.

Structure en bois recouverte de mousse de polyuréthane non feu à densités différenciées. Pieds en métal verni aluminium. L'élément n'est pas déhoussable.

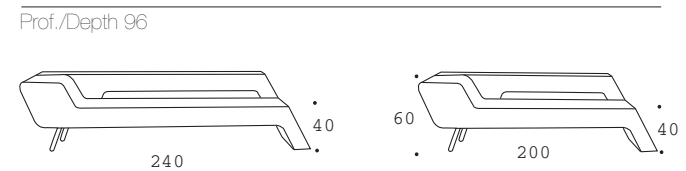

Un'accentuazione dinamica, un procedimento di progetto applica in modo concettuale alla realtà produttiva, in una fusione di continuità, linee segmentate orizzontali e oblique. Il risultato inusuale ha una forte presenza nell'ambiente.

A dynamic emphasis, a design procedure strictly related to manufacturing reality in a mix of lines stretching out in various directions. The unusual result has a deep impact on the living space.

Une accentuation dynamique, un procédé de projet tout à fait lié à la réalité productive, dans un fusion de lignes morcelées, horizontales et obliques. L'insolite résultat est une remarquable présence dans le milieu.



flexy
design Davide Tonizzo



Fusto in legno rivestito in poliuretano espanso
ignifugo indeformabile a densità differenziata.
Piede in metallo verniciato alluminio.
Il modello è sfoderabile.

Wooden frame covered with stressresistent
polyurethane foam at varied densities.
Flame retardant. Feet in metal polished aluminium.
Removable covers.

Structure en bois recouverte de
mousse de polyuréthane non feu
à densités différenciées.
Pieds en métal verni aluminium.
L'élément est déhoussable.

Prof./Depth 88

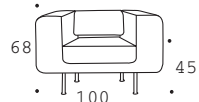
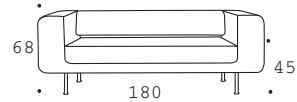
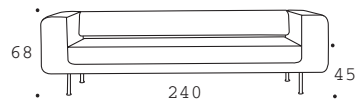

Orizzontale, orizzontale decisamente orizzontale.
Flexy in blu è la calma del mare senza vento.
È un segno con rapide curve, lunghi piani e
brevi masse alleggerite dallo spazio vuoto tra
seduta e schienale. È una figura esclusiva per
le zone d'attesa.

Horizontal, horizontal and horizontal again.
Flexy in blue looks like a windless sea. It is a
rapidly bending sign, a mix of long planes
and compact volumes eased by the space
between seat and back, it is an unique shape
for waiting areas.

Horizontale, horizontale, décidément horizontale.
Flexy en bleu est le calme de la mer sans
vent. C'est un signe qui se courbe rapidement,
qui forme des plans étendus et des masses
compactes, soulagées par l'espace vide
entre le siège et le dossier. C'est une
forme exclusive pour les zones d'attente.

robespierre

design Studio Galantini



Fusto in legno rivestito in poliuretano espanso
ignifugo indeformabile a densità differenziata.
Piede in acciaio cromato.
Il modello non è sfoderabile.

Wooden frame covered with stressresistent polyurethane
foam at varied densities. Flame retardant.
Legs in steel cromate finish.
No removable covers.

Structure en bois recouverte de mousse de
polyuréthane non feu à densités différenciées.
Pieds en acier chromé.
L'élément n'est pas déhoussable.

Prof./Depth 80

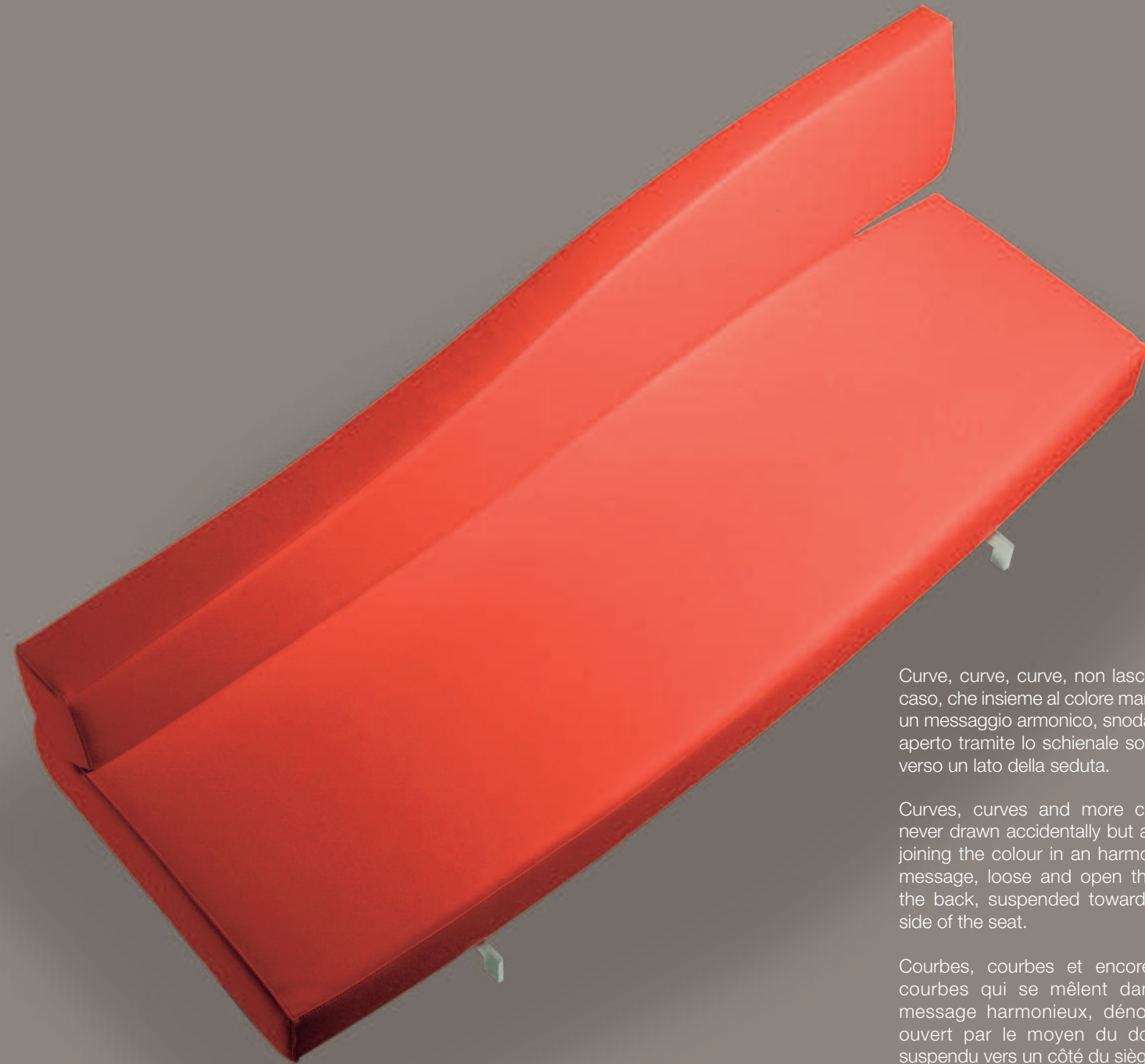
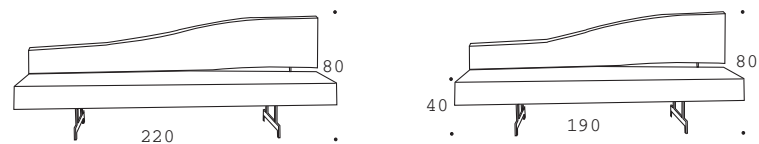

Curve, curve, curve, non lasciate al
caso, che insieme al colore mandano
un messaggio armonico, snodato ed
aperto tramite lo schienale sospeso
verso un lato della seduta.

Curves, curves and more curves,
never drawn accidentally but always
joining the colour in an harmonious
message, loose and open through
the back, suspended towards one
side of the seat.

Courbes, courbes et encore des
courbes qui se mêlent dans un
message harmonieux, dénoué et
ouvert par le moyen du dossier,
suspendu vers un côté du siège.

A photograph of a modern interior space. In the foreground, a long, low-profile sofa with a vibrant red fabric is positioned. The sofa has a curved backrest and is supported by thin, dark metal legs. Behind the sofa, a large window with a white frame and a decorative metal structure (a circle with four lines radiating from it) is visible. The window looks out onto a cityscape with buildings and a grid-like pattern, possibly a window blind or a reflection. The lighting is soft and even, highlighting the texture of the sofa and the architectural details.

HEMINGWAY AVREBBE MODIFICATO IL TITOLO DEL SUO RACCONTO
IN "ROSSE COLLINE D'AFRICA"



bibi - barny
design Giorgio Manzali

Acciaio rivestito in poliuretano espanso
ignifugo indeformabile a densità differenziata.
Piede in acciaio verniciato.
Il modello non è sfoderabile.

Steel frame covered with stressresistent
polyurethane foam at varied densities.
Flame retardant.
Legs in metal polished aluminium.
No removable covers.

Structure en acier recouverte de mousse de
polyuréthane non feu à densités différenciées.
Pieds en métal verni aluminium.
L'élément n'est pas déhoussable.

Prof./Depth 85



LUCI DELLA CITTA'
E CURVE D'ATTESA IN VERDE



bench

design Studio Galantini



Fusto in legno rivestito in poliuretano espanso
ignifugo indeformabile a densità differenziata.
Piede in polipropilene.
Il modello non è sfoderabile.

Wooden frame covered with stressresistent polyurethane
foam at varied densities. Flame retardant.
Feet are in polypropilene.
No removable covers.

Structure en bois recouverte de mousse de polyuréthane
non feu à densités différenciées.
Pieds en polypropylène.
L'élément n'est pas déhoussable.

Prof./Depth 85

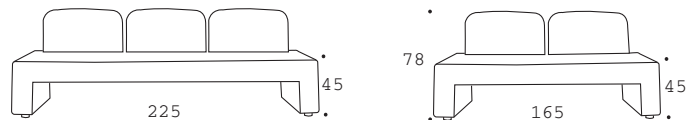

UN PONTE ROSSO COMUNICA, DECISO,
SENZA ORNAMENTI, SOLIDA LEGGEREZZA



gente che va,
gente che viene
gente che guarda altra gente,
lo spazio è sereno...

People going
People coming
People watching other people
The space is peaceful.

Gens qui vont
Gens qui viennent
Gens qui se regardent
L'espace est serein

ruby

design Studio Galantini



Fusto in legno rivestito in poliuretano espanso
ignifugo indeformabile a densità differenziata.
Piede in polipropilene.
Il modello non è sfoderabile.

Wooden frame covered with stressresistent polyurethane
foam at varied densities. Flame retardant.
Feet are in polypropilene.
No removable covers.

Structure en bois recouverte de mousse de polyuréthane
non feu à densités différenciées.
Pieds en polypropylène.
L'élément n'est pas déhoussable.

Prof./Depth 85

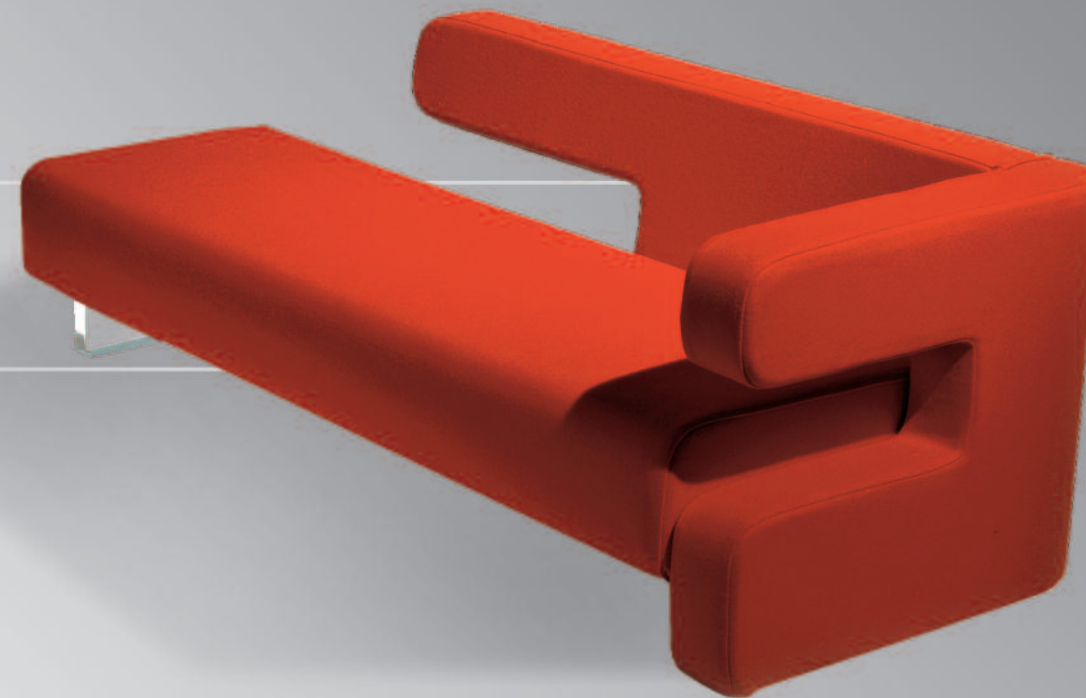
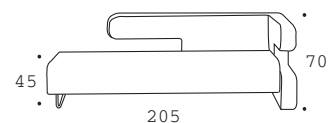
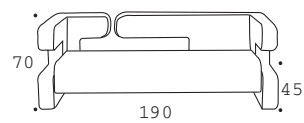
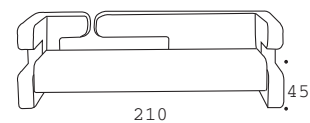

Ruby divano o chaise longue per molti ospiti, sottolinea che forma e colore vivificano l'ambiente non solo come funzione strumentale. Ruby quasi non sembra progettato a tavolino ma realizzato con volumi aperti direttamente nello spazio.

Ruby, sofa and chaise lounge for many guests, showing that form and colour enliven the space not only as functional tools. It seems that Ruby hasn't been designed on the drawing table, but built up with volumes stretching directly into the space.

Ruby canapé ou chaise longue pour beaucoup d'hôtes, évidence que forme et couleur vivifie l'ambiance pas uniquement comme fonction instrumental. Ruby ne parait pas projeté au bureau mais réalisé directement dans l'espace.



DO YOU WANT TO SPEAK WITH ME NEAR THE SKY?

tobago
design Giorgio Manzani



Fusto in legno rivestito in poliuretano espanso
ignifugo indeformabile a densità differenziata.
Piede in metallo verniciato alluminio.
Il modello non è sfoderabile.

Wooden frame covered with stressresistent polyurethane
foam at varied densities. Flame retardant.
Feet in metal polished aluminium.
No removable covers.

Structure en bois recouverte de mousse de polyuréthane
non feu à densités différenciées.
Pieds en métal verni aluminium.
L'élément n'est pas déhoussable.

Prof./Depth 100

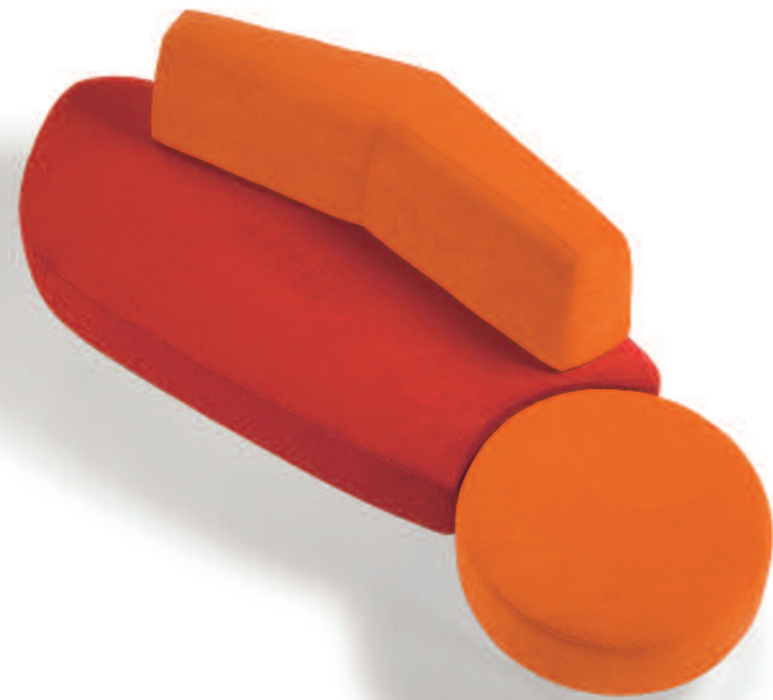
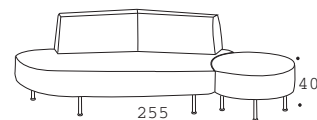

LEGGERI O FORTI CONTRASTI DI COLORE LEGANO LINEE CURVE
A SEGMENTI FLESSIBILI



eoos

design Giorgio Manzoni



Fusto in legno con molleggio a doghe in faggio rivestito
in poliuretano espanso ignifugo indeformabile a densità differenziata.
Piede in metallo verniciato alluminio.
Il modello non è sfoderabile.

Wooden frame, suspension with beech wood slats covered
with stressresistant polyurethane foam at varied densities.
Flame retardant.
Legs in metal polished aluminium.
No removable covers.

En bois suspension avec douves en hêtre recouverte de
mousse de polyuréthane non feu à densités
différenciées.
Pieds en métal verni aluminium.
L'élément n'est pas déhoussable.

Prof./Depth 83

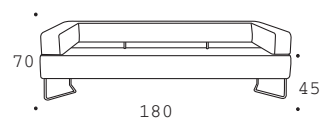
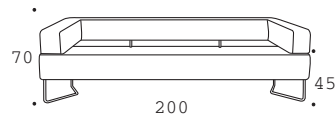
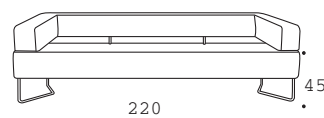



Due segni orizzontali: seduta e schienale, due segni obliqui: i braccioli, attraverso l'incisività del rosso indicano una scelta di campo netta e chiara cioè la sintesi delle forme. Eos è un'architettura che si fa divano attraverso geometrie di elementi rigorosi ed essenziali.

Two horizontal lines for seat and back, two slanting lines for the armrests. Through the sharpness of the red colour they underline a clear and definite choice, that means the synthesis of forms. Eos is an architecture becoming a sofa through rigorous and strict signs.

Deux signes horizontales, siège et dossier; deux signes obliques, les accoudoirs. Avec la force du rouge ils indiquent un choix net et clair, la synthèse des formes. Eos est une architecture qui devient canapé par une géométrie d'éléments rigoureux et essentiels.

LA MATITA CHE PROGETTA RUOTA VELOCE SU SE STESSA

E SCATTA VERSO L'ALTO

barbados
design Giorgio Manzali

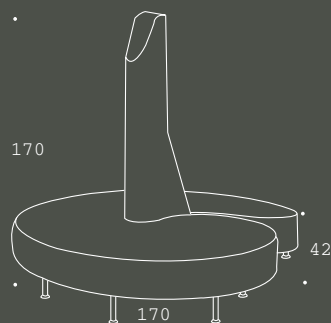

Fusto in legno rivestito in poliuretano espanso ignifugo indeformabile a densità differenziata. Piede in metallo verniciato alluminio. Il modello non è sfoderabile.

Wooden frame covered with stressresistent polyurethane foam at varied densities. Flame retardant. Feet in metal polished aluminium. No removable covers.

Structure en bois recouverte de mousse de polyuréthane non feu à densités différenciées. Pieds en métal verni aluminium. L'élément n'est pas déhoussable.





ROLLY: UN'IDEA PER SEDERSI NATA DALLA FORMA DI UN OROLOGIO DOPO L'ORA DI PRANZO

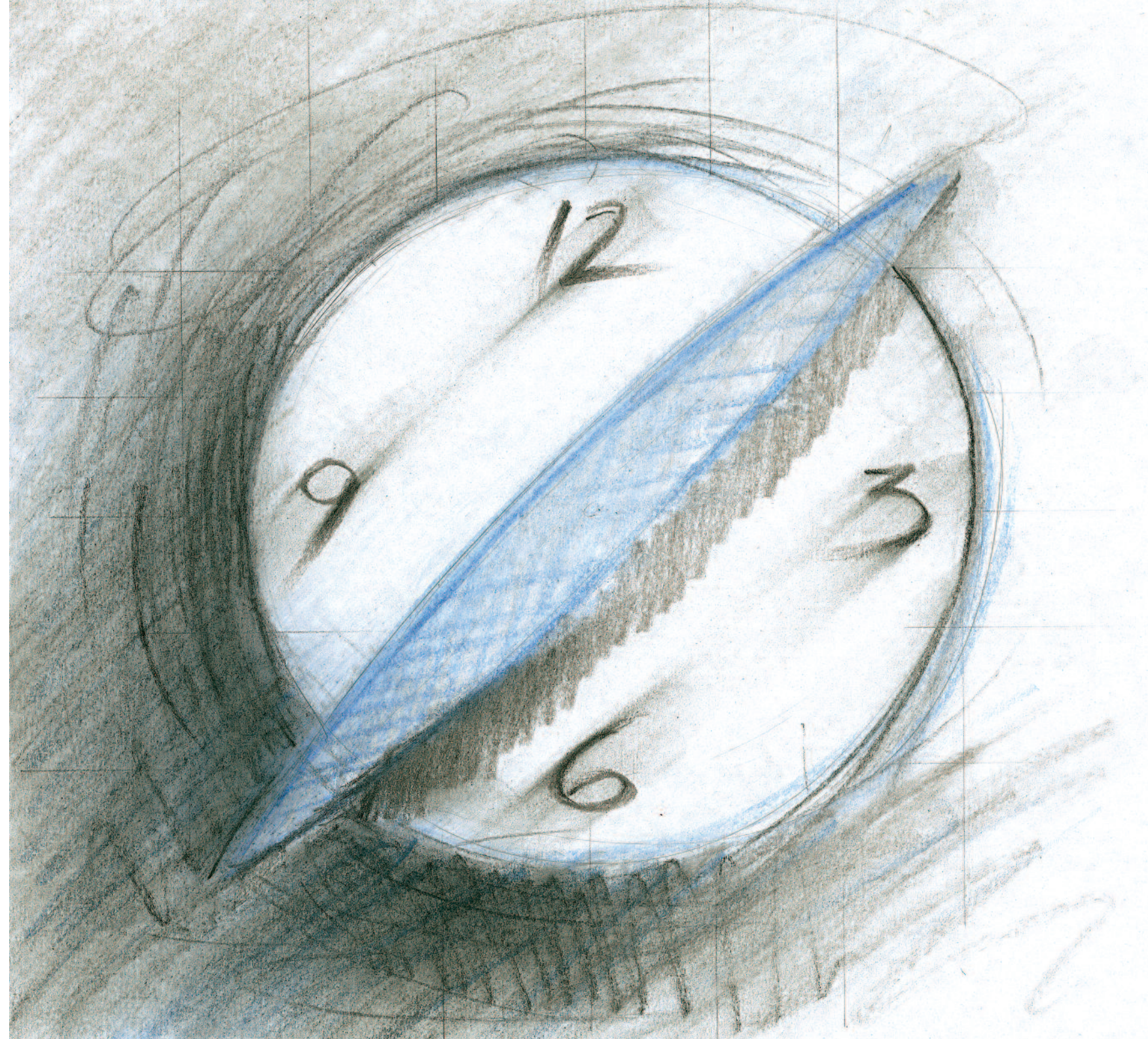



rolly

design Giorgio Manzali



Fusto in legno rivestito in poliuretano espanso ignifugo indeformabile a densità differenziata. Piede in acciaio cromato. Il modello non è sfoderabile.

Wooden frame covered with stressresistent polyurethane foam at varied densities. Flame retardant. Feet are in chromed steel. No removable covers.

Structure en bois recouverte de mousse de polyuréthane non feu à densités différenciées. Pieds en acier déhoussable. L'élément n'est pas déhoussable.

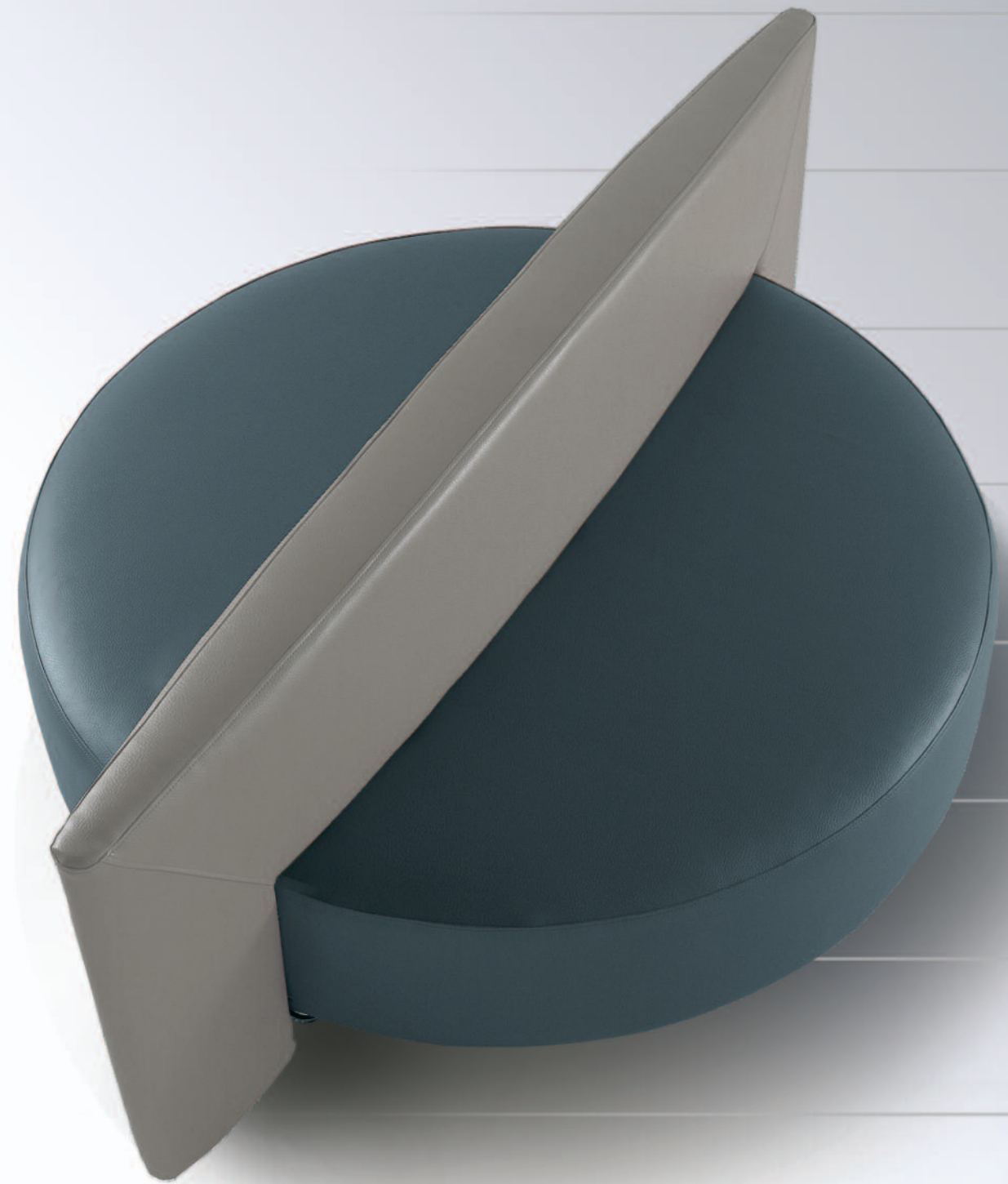
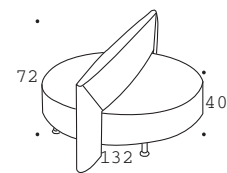



GUARDARSI IN FACCIA,
POSSIBILITÀ DI

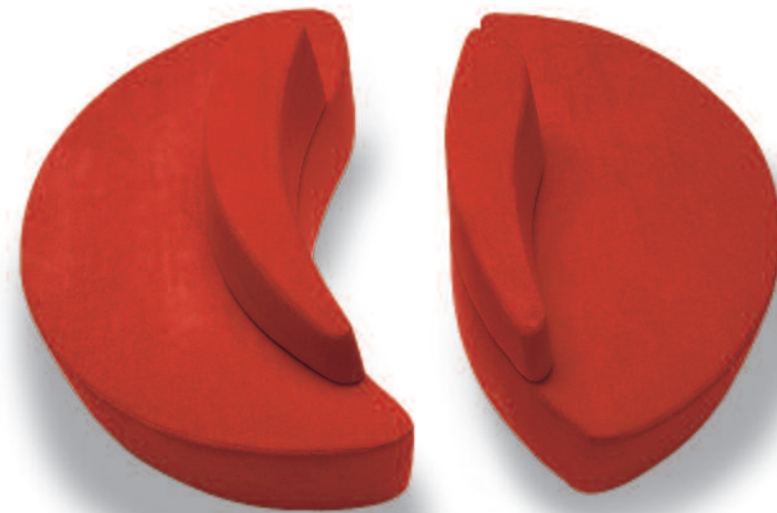

helis

design Giorgio Manzali

Fusto in legno rivestito in poliuretano espanso
ignifugo indeformabile a densità differenziata.
Piede in polipropilene.
Il modello non è sfoderabile.

Wooden frame covered with stressresistent polyurethane
foam at varied densities. Flame retardant.
Feet are in polypropilene.
No removable covers

Structure en bois recouverte de mousse de polyuréthane
non feu à densités différenciées.
Pieds en polypropylène.
L'élément n'est pas déhoussable.

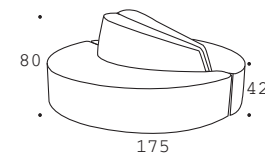

VOLTARSI LE SPALLE, AVVICINARSI:
UN GRANDE POUF-DIVANO PER ATTESA DA CENTRO STANZA





UNA SCULTURA DA CENTRO STANZA PER UN GESTO DI OGNI MOMENTO DEL GIORNO: *SEDESI.*
A SCULPTURE TO BE POSITIONED IN THE CENTER OF THE ROOM FOR A TIMELESS HABIT: *TO TAKE A SEAT.*
UNE SCULPTURE PLACÉE AU MILIEU DE LA CHAMBRE POUR UN GESTE DE CHAQUE MOMENT DU JOUR: *S'ASSEOIR.*

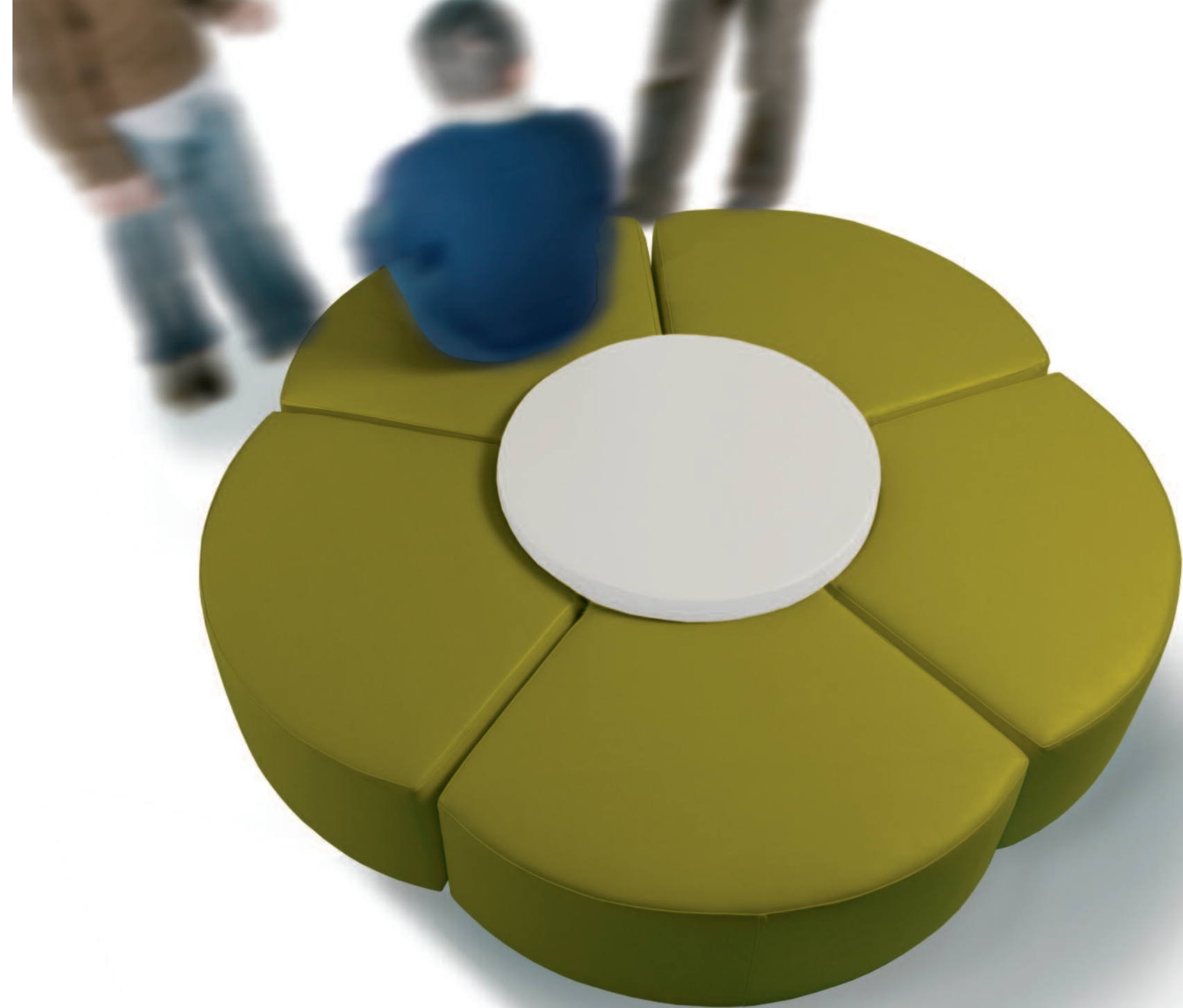
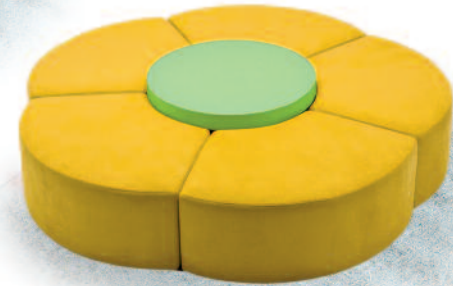
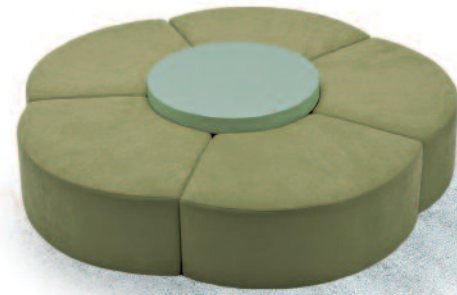

daisy

design Giorgio Manzali

Fusto in legno rivestito in poliuretano espanso
ignifugo indeformabile a densità differenziata.
Piede in polipropilene.
Il modello non è sfoderabile.

Wooden frame covered with stressresistent
polyurethane foam at varied densities.
Flame retardant.
Feet are in polypropilene.
No removable covers

Structure en bois recouverte de mousse de
polyuréthane non feu à densités différenciées.
Pieds en polypropylène.
L'élément n' est pas déhoussable.

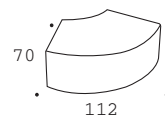
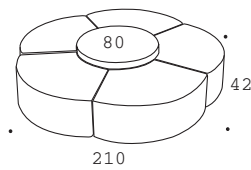

UN FIORE CHE SI APRE E I PETALI SI TRASFORMANO



IN UN SERPENTE INFINITO;
EVA AL MOMENTO NON È PRESENTE





fred
design Giorgio Manzoni



Fusto in legno rivestito in poliuretano espanso ignifugo indeformabile a densità differenziata. Piede in metallo verniciato alluminio. Il modello non è sfoderabile.

Wooden frame covered with stressresistent polyurethane foam at varied densities. Flame retardant. Feet in metal polished aluminium. No removable covers.

Structure en bois recouverte de polyuréthane non feu à densités différenciées. Pieds en métal verni aluminium. L'élément n'est pas déhoussable.

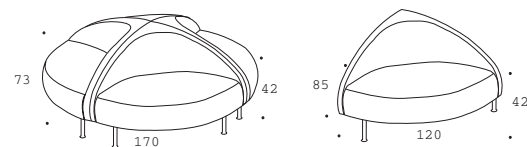

grande pouf scomponibile da centro e da parete
a big sectional footstool, to be used centrally or along the wall
grand pouf par éléments, utilisable au centre ou bien au mur

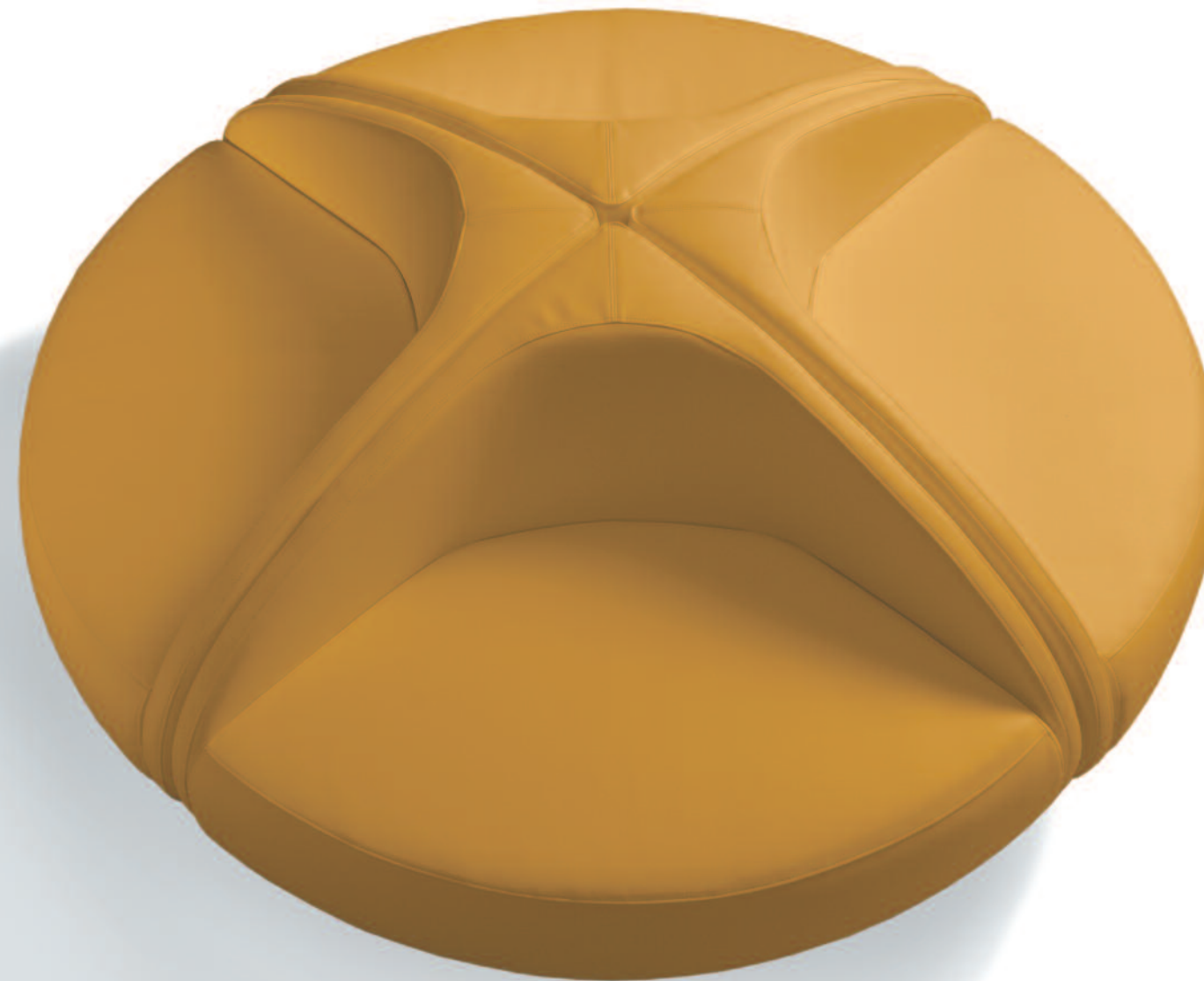

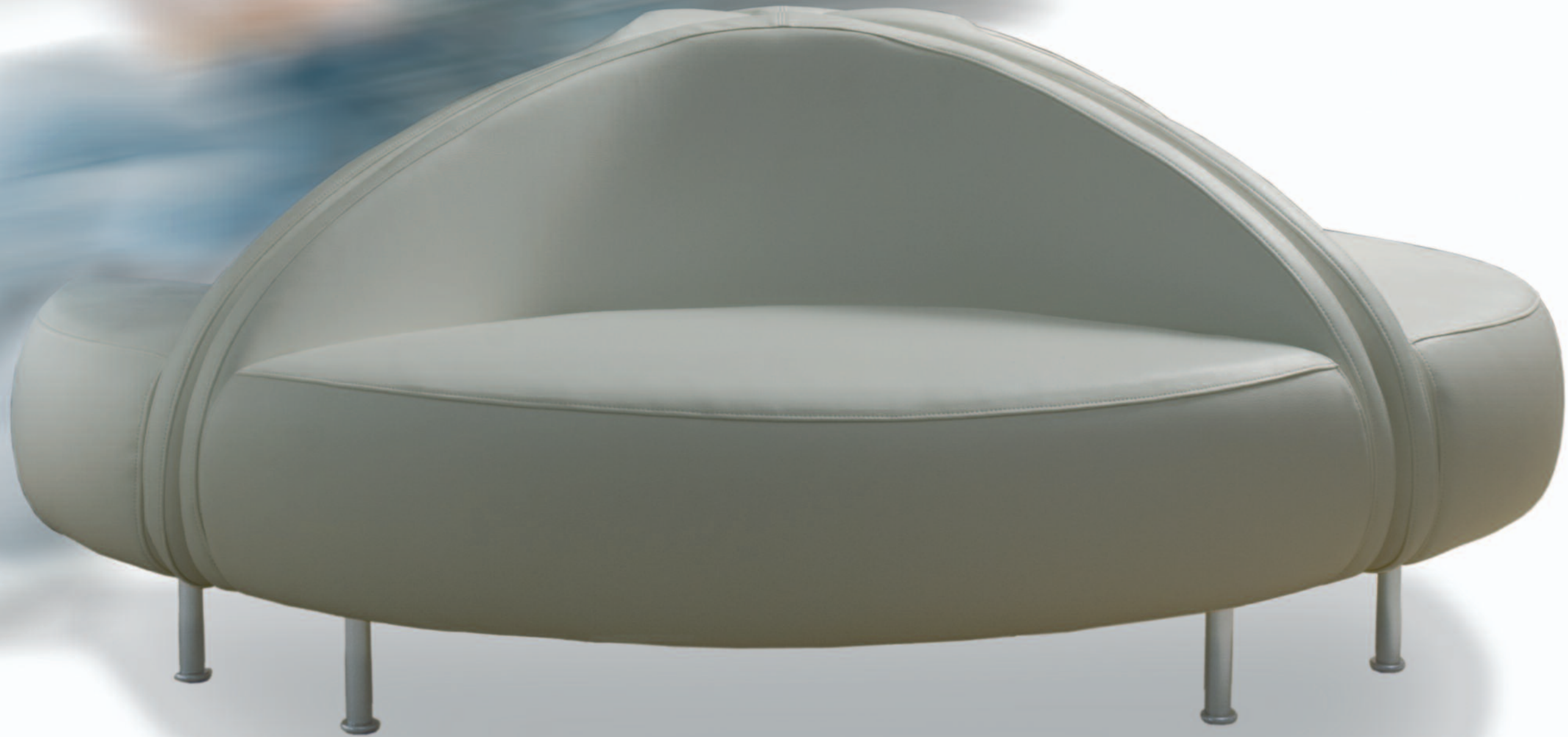

PRONTO A DIVIDERM
E A DISPORMI COME NECESSARIO
PER ANGOLO ESTERNO 1
PARETE PIANA 2
ANGOLO INTERNO 3

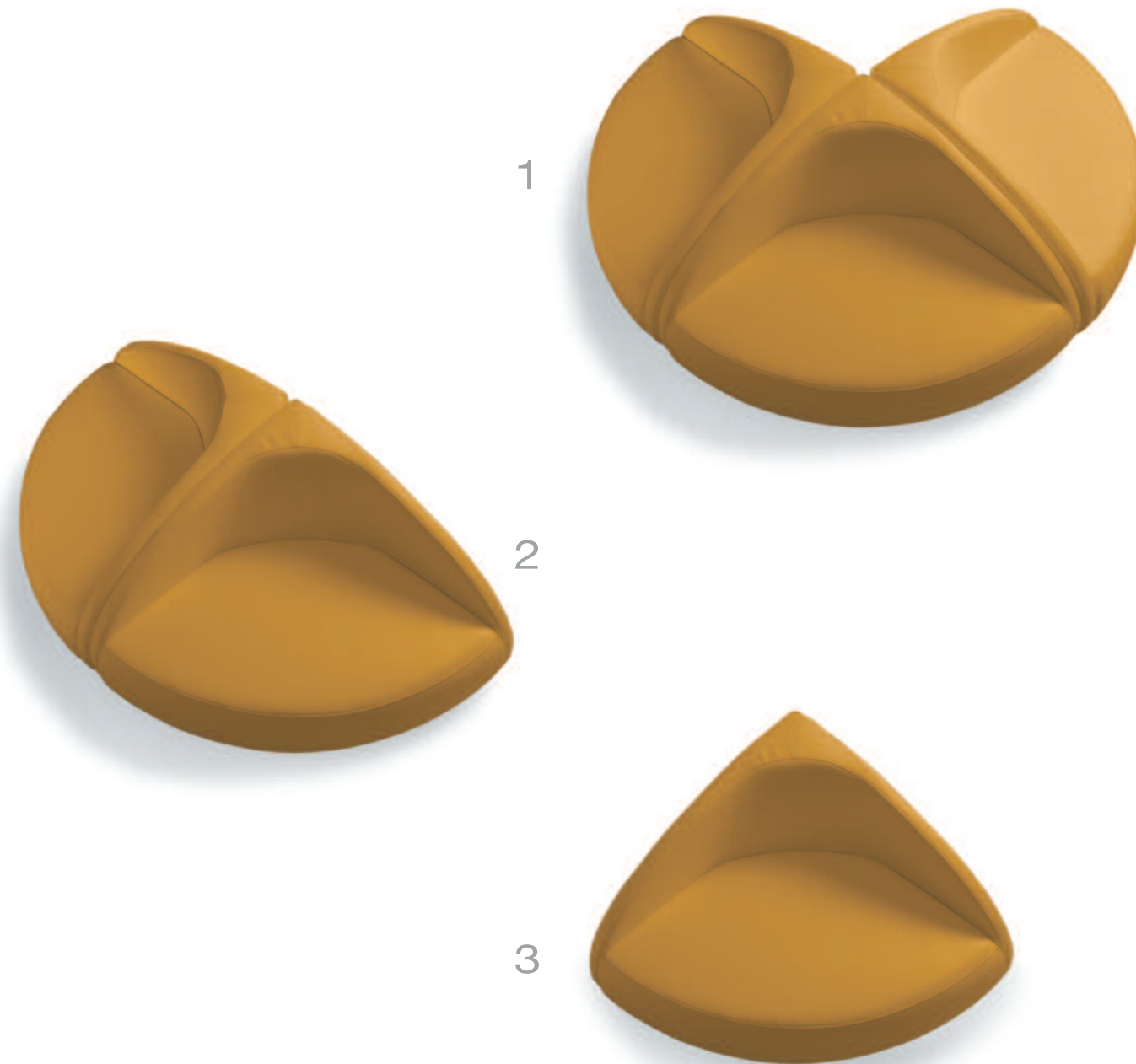
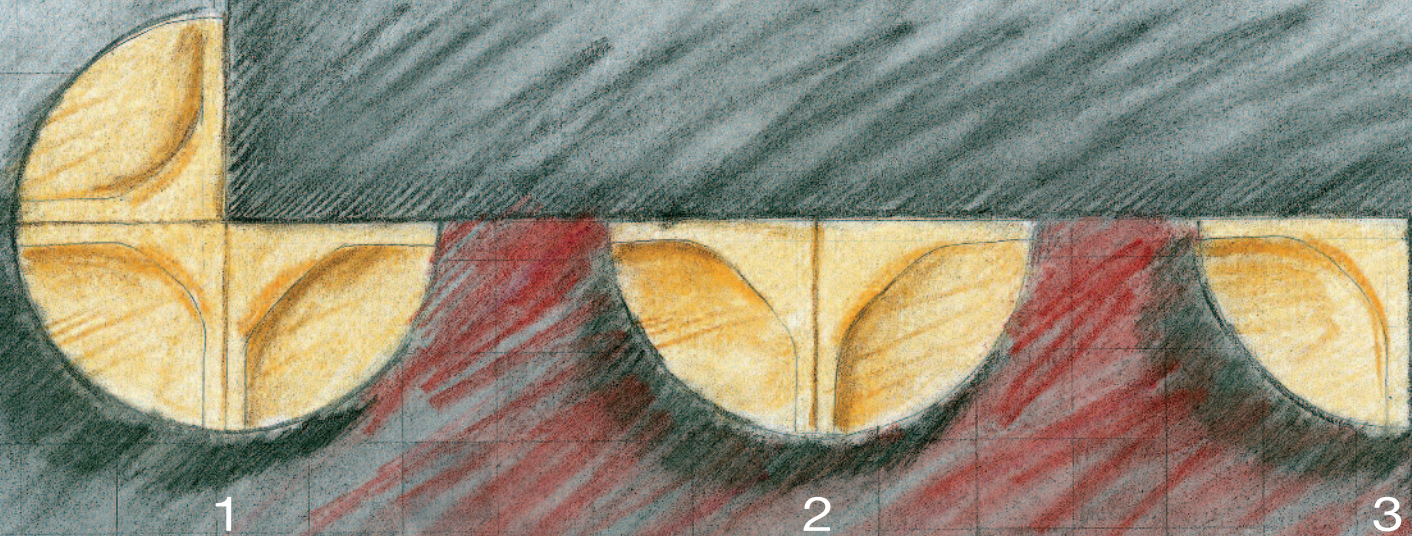



dominica - martinica
design Giorgio Manzali

Fusto in legno rivestito in poliuretano espanso ignifugo indeformabile a densità differenziata. Piede in metallo verniciato alluminio. Il modello non è sfoderabile.

Wooden frame covered with stressresistent polyurethane foam at varied densities. Flame retardant. Feet in metal polished aluminium. No removable covers.

Structure en bois recouverte de mousse de polyuréthane non feu à densités différenciées. Pieds en métal verni aluminium. L'élément n'est pas déhoussable.

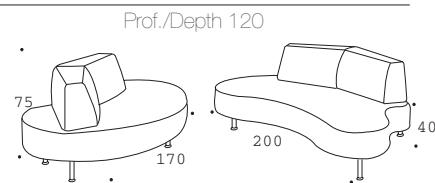

punto

design Studio Galantini



Fusto in legno rivestito in poliuretano espanso
ignifugo indeformabile a densità differenziata.
Piede in metallo verniciato alluminio.
Il modello non è sfoderabile.

Wooden frame covered with stressresistant polyurethane
foam at varied densities. Flame retardant.
Legs are in metal polished aluminium.
No removable covers.

Structure en bois recouverte de mousse de polyuréthane
non feu à densités différenciées.
Pieds en métal verni aluminium.
L'élément n'est pas déhoussable.

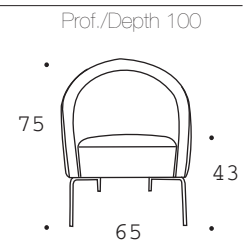

STUDI PROPORZIONALI SULLO SCHIENALE, ELEMENTO CHE CARATTERIZZA LO POLTRONCINE COFFEE

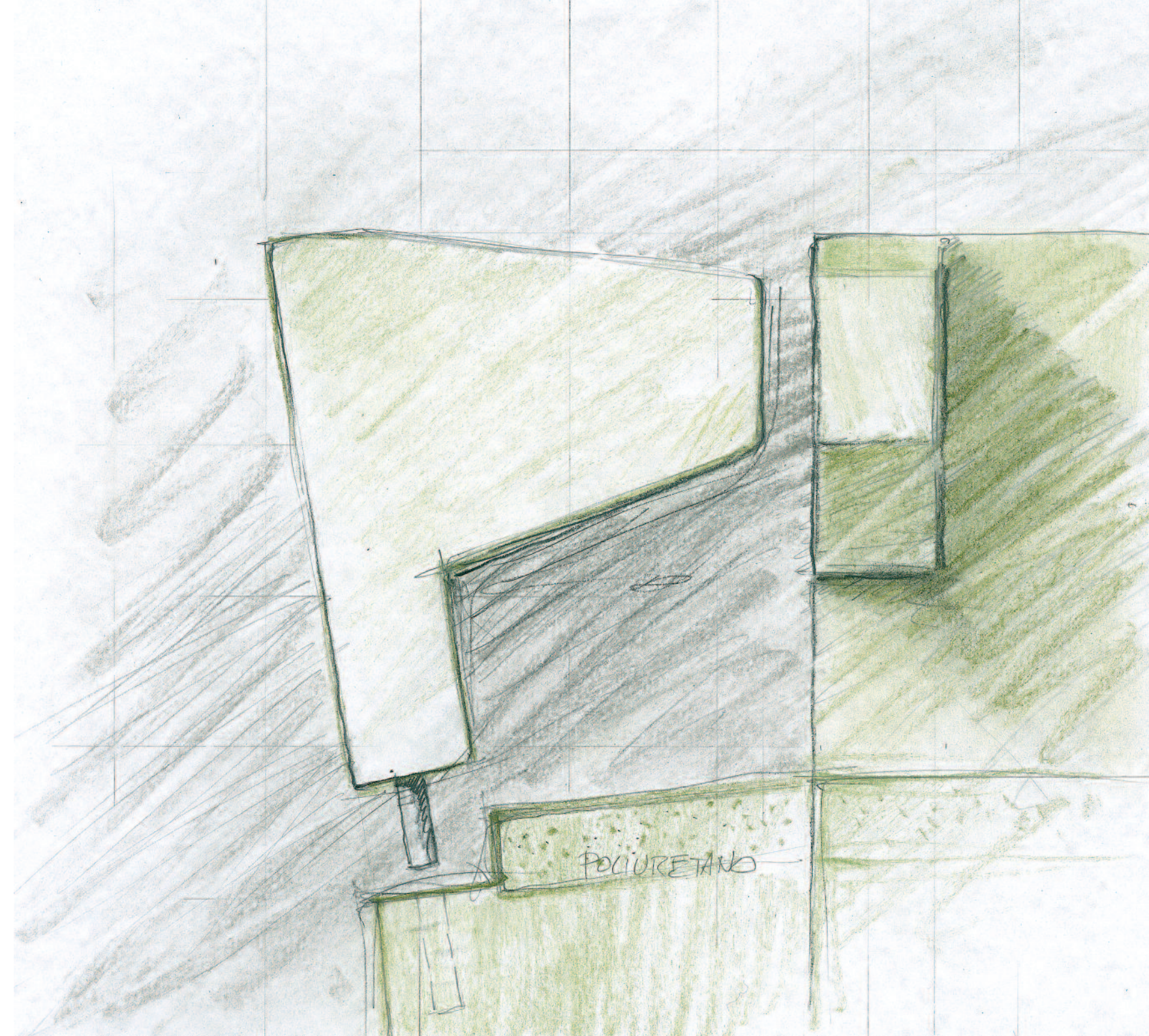

coffe one two three

design Giorgio Manzali

Fusto in legno rivestito in poliuretano espanso
ignifugo indeformabile a densità differenziata.
Piede in metallo verniciato alluminio.
Il modello non è sfoderabile.

Wooden frame covered with stressresistent
polyurethane foam at varied densities. Flame retardant.
Legs are in metal polished aluminium.
No removable covers.

Structure en bois recouverte de mousse de
polyuréthane non feu à densités différenciées.
Pieds en métal verni aluminium.
L'élément n'est pas déhoussable.

Prof./Depth 54

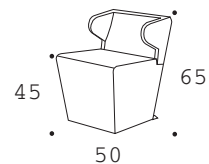

INNOVATIVA COMODA VERSATILE
MISURE MINIME D'INGOMBRO
DI PIACEVOLE CONVERSAZIONE, BEVE MOLTI CAFFÈ



DO YOU WANT TO DRINK
ONE, TWO, THREE COFFEES WITH ME IN NEW YORK?
OH, YES, YES. IT'S POSSIBLE!







cappuccino one - two - three

design Giorgio Manzali

Fusto in legno rivestito in poliuretano espanso
ignifugo indeformabile a densità differenziata.
Basamento girevole in acciaio satinato.
Il modello è sfoderabile.

Wooden frame covered with stressresistent polyurethane
foam at varied densities. Flame retardant.
Feet in metal polished aluminium.
Removable covers.

Structure en bois recouverte de mousse de polyuréthane
non feu à densités différenciées.
Pieds en métal verni aluminium.
L'élément est déhoussable.

Prof./Depth 54

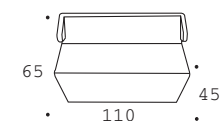

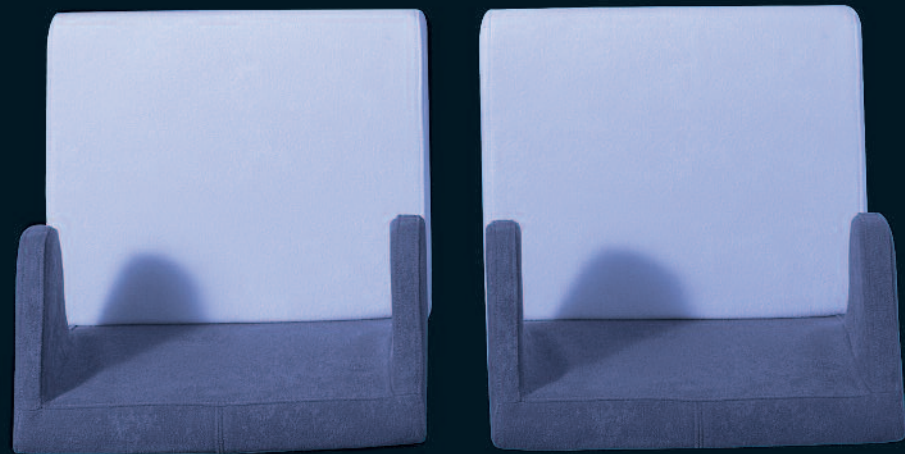

Poltroncine e divanetti per zone conversazione in ambienti pubblici, caffè, pasticcerie studiati come elementi funzionali e vivificanti, per forma e colore.

Small armchairs and sofas for conversation areas in public rooms like bars and pastry shops, designed as functional and decorative units.

Petites fauteuil et canapés pour la zone conversation de locaux publics, bars pâtisseries, dessinés comme éléments fonctionnels et décoratifs.





carla - carlotta
design Studio Galantini

Fusto in legno rivestito in poliuretano espanso
ignifugo indeformabile a densità differenziata.
Piede in polipropilene. Il modello non è sfoderabile.

Wooden frame covered with stressresistent polyurethane
foam at varied densities. Flame retardant.
Feet are in polypropilene. No removable covers.

Structure en bois recouverte de mousse de polyuréthane
non feu à densités différenciées.
Pieds en polypropylène. L'élément n'est pas déhoussable.

Prof./Depth 59

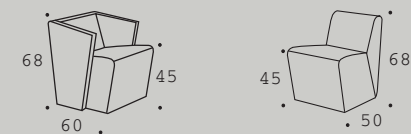

HELLO BOYS! A LITTLE BREAK WITH CARLA AND CARLOTTA?





hug-me

design Daniele Menichini

Fusto in legno rivestito in poliuretano espanso
ignifugo indeformabile a densità differenziata.
Piede in metallo verniciato alluminio.
Il modello non è sfoderabile.

Wooden frame covered with stressresistent polyurethane
foam at varied densities. Flame retardant.
Legs are in metal polished aluminium.
No removable covers.

Structure en bois recouverte de mousse de polyuréthane
non feu à densités différenciées.
Pieds en métal verni aluminium.
L'élément n' est pas déhoussable.

Prof./Depth 75

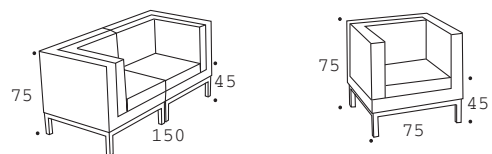

Poltrone progettate per hall. Ruotando la parte interna amovibile,
in colore diverso nella foto, si ottiene una poltrona con un solo
bracciolo che, accostata ad un'altra, forma un divanetto a due
posti.

Armchair designed for hotel lobbies. The kidney cushion can
be moved laterally and becomes an armrest, thus giving the
possibility of building up a loveseat by joining two units.

Fauteuils projetés pour hall d'hôtels. En le tournant, le cale reins
se transforme en accoudoir et en utilisant deux éléments
on peut donc obtenir un canapé deux places.

VADO AL BAR, CAPPUCCINO BRIOCHE E SPREMUTA
NON CAMBIO UNA VIRGOLA

virgola
design Studio Galantini

Fusto in legno rivestito in poliuretano espanso
ignifugo indeformabile a densità differenziata.
Piede in polipropilene. Il modello non è sfoderabile.

Wooden frame covered with stressresistent polyurethane
foam at varied densities. Flame retardant.
Feet are in polypropilene. No removable covers.

Structure en bois recouverte de mousse de polyuréthane
non feu à densités différenciées.
Pieds en polypropylène. L'élément n'est pas déhoussable.

Prof./Depth 57

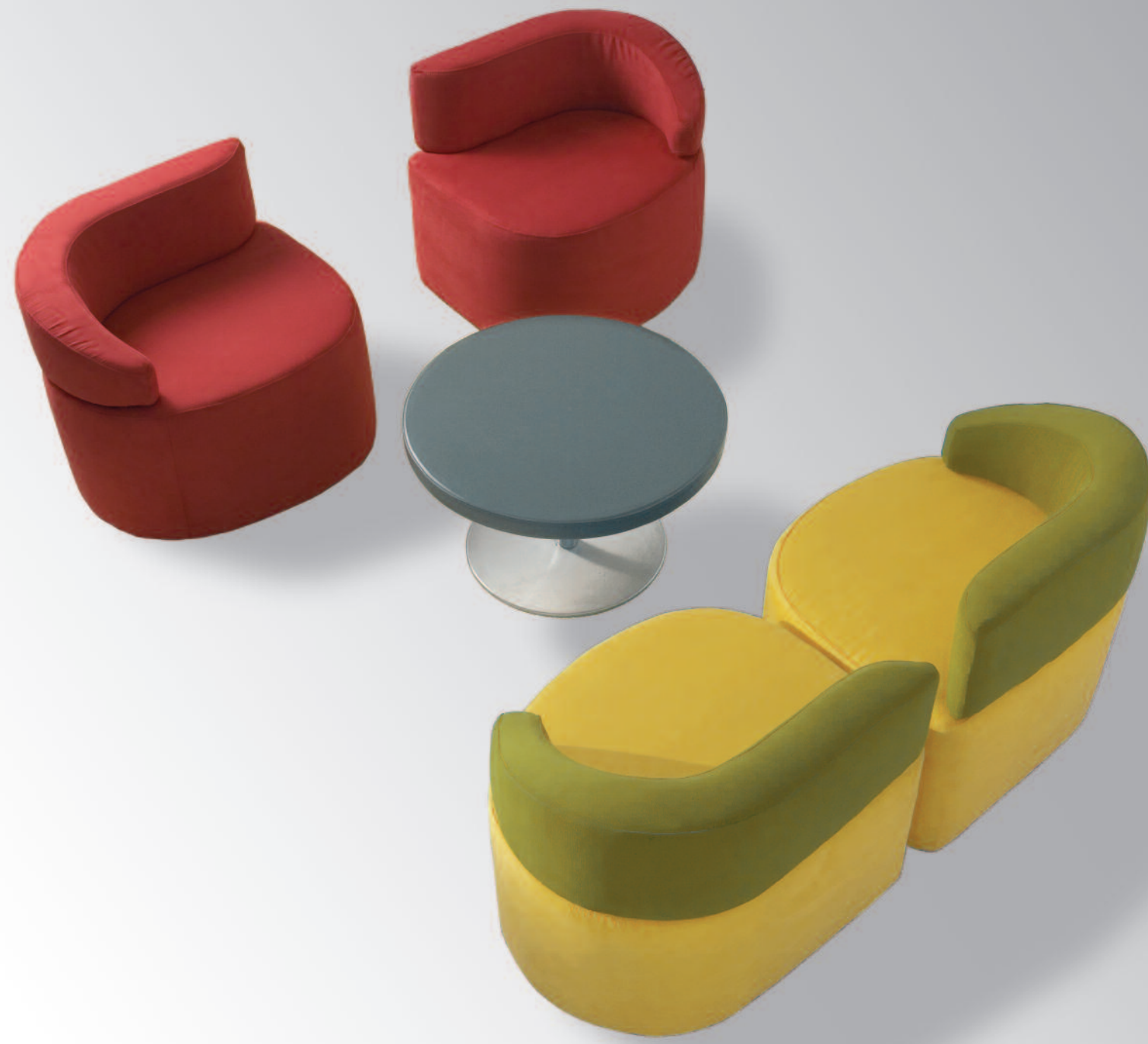
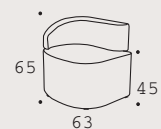



trace big & small
design Studio Galantini

Fusto in legno rivestito in poliuretano espanso
ignifugo indeformabile a densità differenziata.
Piede in acciaio cromato.
Il modello non è sfoderabile.

Wooden frame covered with stressresistent polyurethane
foam at varied densities. Flame retardant.
Feet are in chromed steel.
No removable covers.

Structure en bois recouverte de mousse de polyuréthane
non feu à densités différenciées.
Pieds en acier déhoussable.
L'élément n° est pas déhoussable.

Prof./Depth 70 small - 75 big

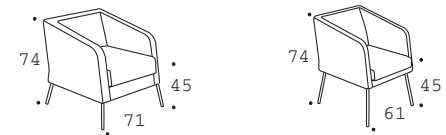



frutta & verdura
design Giorgio Manzali

Pouf in poliuretano su ruote. Le idee originali sono le più semplici o le più antiche o le più qualcos'altro. Frutta & Verdura sono un gruppo di naturalisti organizzati da usare come pouf per sedersi, per stendere le gambe, per giocare, per ridere.

Footstool on casters, simple and ancient like all original ideas. Frutta & Verdura (Fruits & Vegetables) are a group of organized naturalia on which you can seat, play cards, stretch your legs, amuse yourself and much more...

Poufs en polyuréthane sur roulettes. Les idées originelles sont toujours les plus simples ou les plus anciennes. Frutta & Verdura (Fruits & Légumes) sont un group de naturalistes organisés, à utiliser comme pouf pour s'asseoir, pour allonger les jambes, pour jouer aux cartes, pour s'amuser et beaucoup d'autre...

110x67x45 h



l'anguria

95x85x45 h



la mela

100x75x45 h

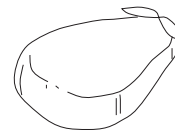

la pera

105x100x45 h



l'uva

85x85x45 h



la zucca

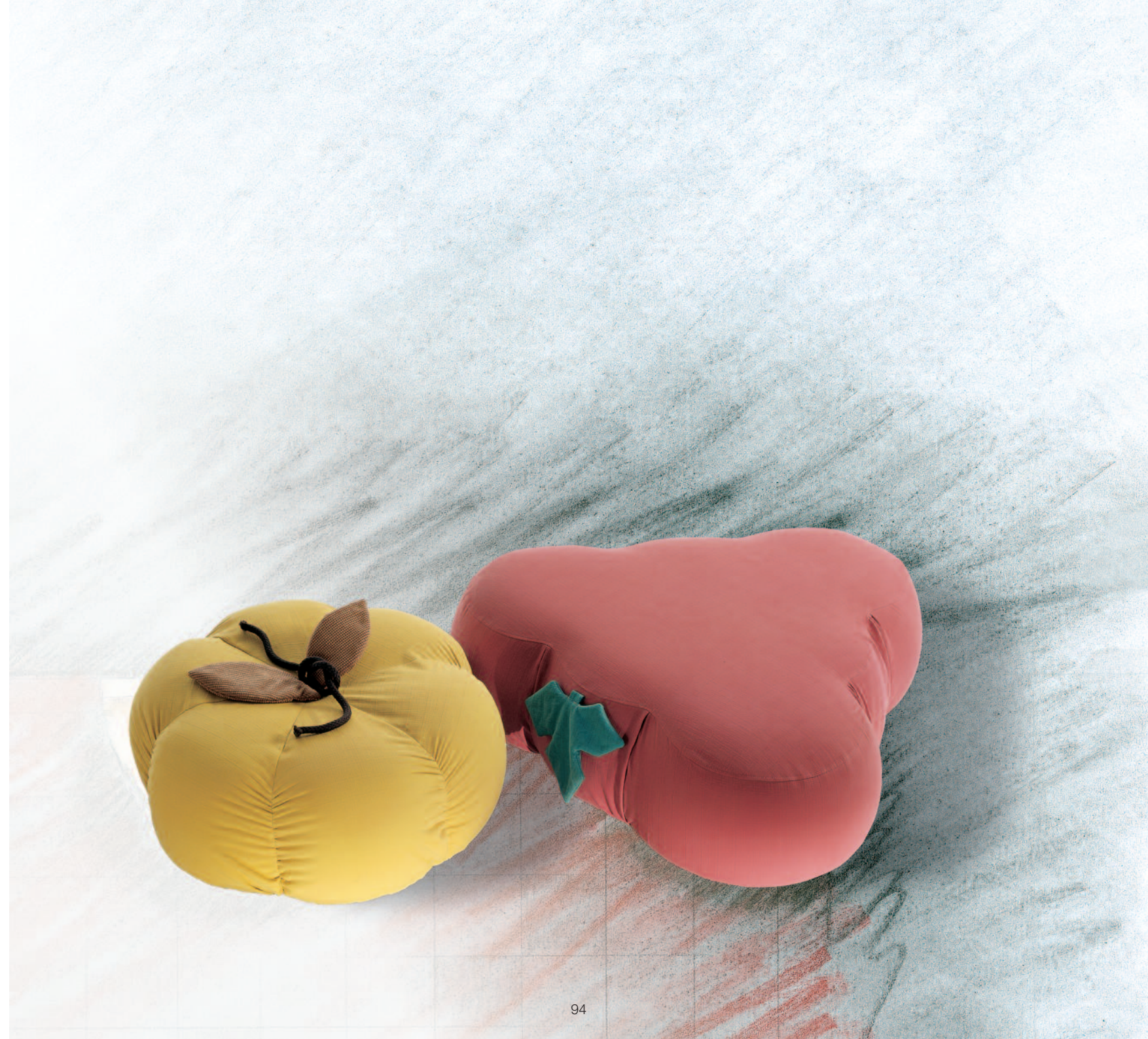

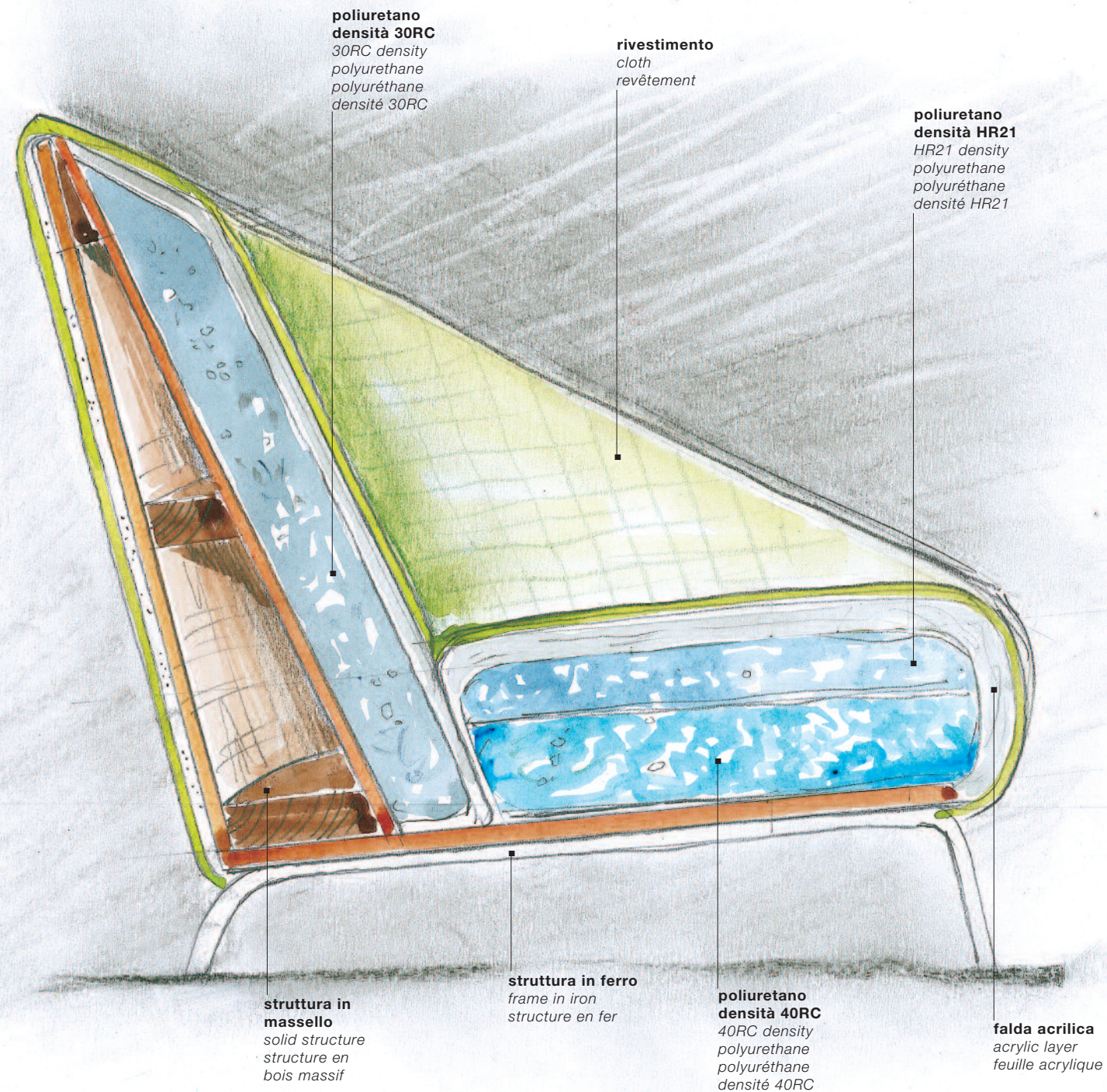

R I E P I L O G A N D O

Il disegno indicante la sezione dei nostri modelli è un'autobiografia illustrata di ciò che e come produciamo.

La figura mostra i materiali usati e come sono realizzate le strutture: *legno massello di pioppo o abete*, e per alcuni parti *legno stratificato*.

Nelle parti morbide usiamo *poliuretani indeformabili ignifughi*; nelle sedute vengono accoppiati con densità diverse, solida quella inferiore (densità 40RC), morbida quella superiore (HR21), mentre per gli schienali una densità media (30RC).

Ogni modello ha una camicia, o sottorivestimento, in tela bianca di cotone, sopra a questo l'abito con il tessuto di rivestimento la cui qualità si può veramente toccare con mano prendendo visione del nostro campionario.

The drawing showing the section of our models is an illustrated autobiography of what we produce and how we produce it.

The figure shows the materials used and the way in which frames are manufactured.

Solid fir or poplar wood and laminated wood for some parts. Soft parts are padded with fireproof and crush-proof polyurethanes coupled into different densities, hard in the lower seat portion (40RC density), soft in the upper seat portion (HR21), and middle density (30RC) in the backrest.

Every model has an under cover, namely a cotton white cloth, and an outer cover made of fabric, whose excellent quality you can see for yourself by looking at our samples.

Le dessin indiquant la section de nos modèles est une autobiographie illustrée de nos produits et de notre mode de production.

La figure montre les matières utilisées et la façon de laquelle nos structures sont réalisées: du bois massif de peuplier ou de sapin et, pour certaines parties, du bois stratifié. Dans les parties souples, des polyuréthanes indéformables ignifuges sont utilisés; dans les assises, ils sont doublés avec des densités différentes: densité haute (40RC) pour la partie inférieure, souple pour la partie supérieure (HR21) et moyenne (30RC) pour les dossiers.

Chaque modèle dispose d'un sous-revêtement en toile de coton blanche, au dessous duquel se trouve une housse dont le tissu a une qualité excellente que vous pouvez vraiment toucher du doigt en regardant nos échantillons.